



POLYTECH.MONS

# Geological storage of Carbon dioxide / nuclear waste

## Part I : The Engineering challenge

ICTP-IAEA joint meeting, Trieste Italy 13 – 18 April 08

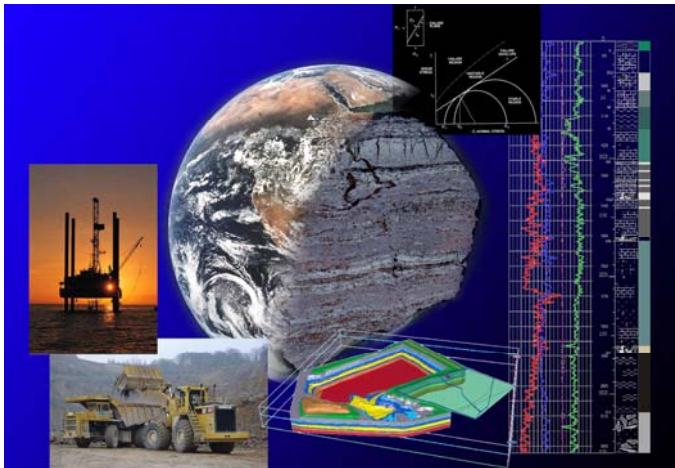

**Jean-Pierre TSHIBANGU K., Dr Ir**

Mining Engineering Dept  
Head of Department  
Faculté Polytechnique de Mons



Génie Minier  
[www.mecaroc.fpms.ac.be](http://www.mecaroc.fpms.ac.be)

FACULTÉ POLYTECHNIQUE DE MONS



ACADÉMIE  
UNIVERSITAIRE  
WALLONIE-  
BRUXELLES

# Content of the presentation

- Introduction
  
- The geological storage of Nuclear waste
  - General storage method
  
  - Shaft sinking and gallery digging
  
- The Geological storage of Carbon dioxide
  - General method of storage
  
  - Drilling and equipping wellbores

## Performing a Geological Storage

The main challenge in addressing the geological storage is finding geological formations that are “porous” enough to host the material to be stored (the porosity can be natural or man made); and the repository or storage has to be surrounded by a barrier to avoid pollution or contamination of aquifers used for water supply.

Each geological formation is characterised by its own physical properties and is subjected, to a certain extent, to transfer of chemicals. In case of waste storage-disposal one must design construction techniques to build secure openings and ensure to have no or very limited leakage in the course of time.

# Content of the presentation

## □ Introduction

## □ The geological storage of Nuclear waste

- General storage method
- Shaft sinking and gallery digging

## □ The Geological storage of Carbon dioxide

- General method of storage
- Drilling and equipping wellbores

# The Nuclear waste material

Radioactive waste typically comprises a number of radioisotopes: unstable configurations of elements that decay, emitting ionizing radiation which can be harmful to human health and to the environment. Those isotopes emit different types and levels of radiation, which last for different periods of time.

The used fuel is conditioned to be non soluble and non chemically reactive by coating in glass material. The material is then put in a metallic container (canister) that can weigh half a metric tonne.

The challenge of geological storage of this material is to ensure that the waste radioactivity does not migrate in the environment by setting a multi-barrier concept.

## General concept of NW repository

The material is to be deposited in a mine like facility by moving the containers from surface to underground. The host geological formation is to be thick and non permeable (tight) enough to ensure the confinement of the waste. The Targeted materials are usually:

Granite like: can be found in massive rock formations, but is always fractured, so the issue of permeability is to be addressed very carefully;

Clay like: Generally impermeable and can be found in thick formations, but the consequences of heating by the waste are to be addressed to avoid an overcooking that can do the material become brittle and fractured;

Salt like: Can be found in massive impermeable geological formations.

# Proposed repository scheme used in Belgium

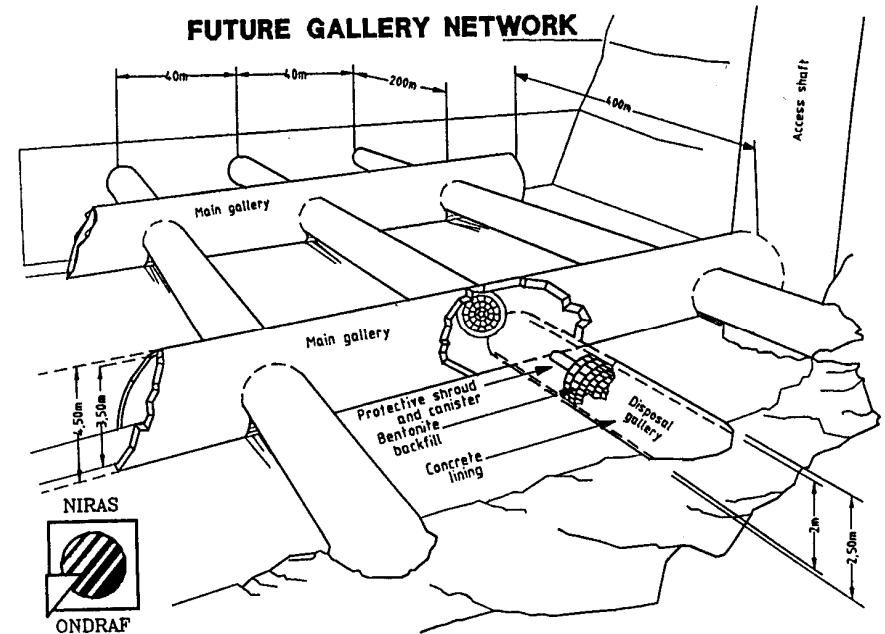
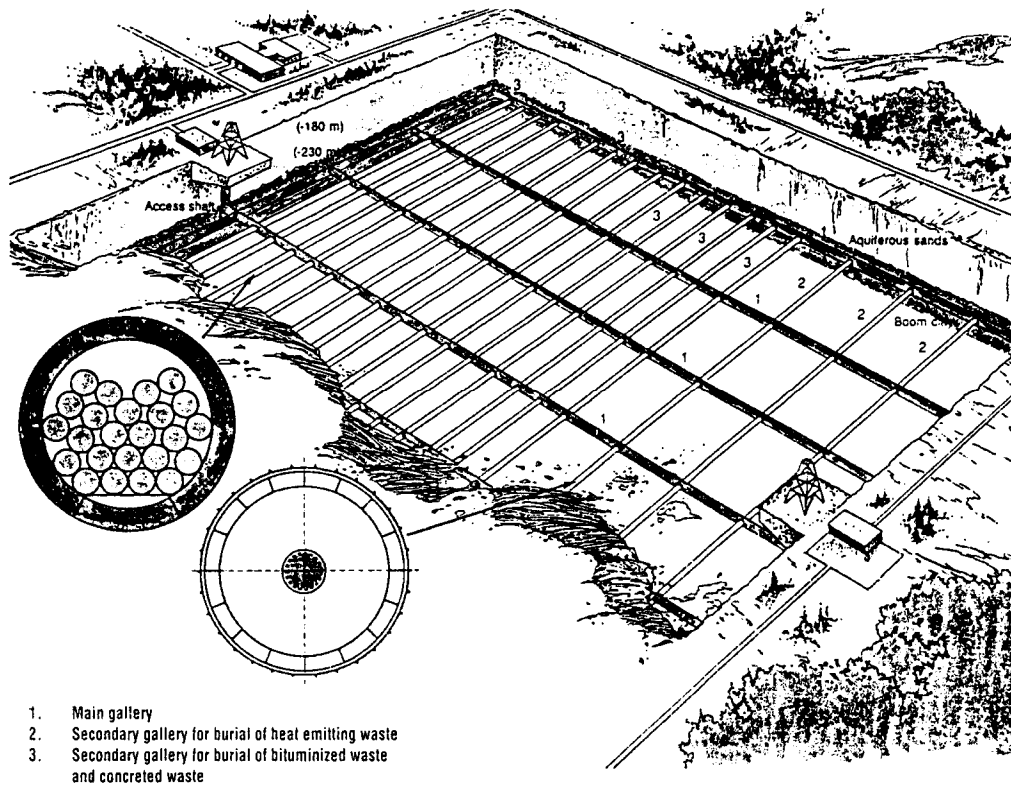

Layout of the general concept to be developed in the Boom Clay

A zoom on the gallery network

# The multi-barrier concept: Praclay experiment in Belgium

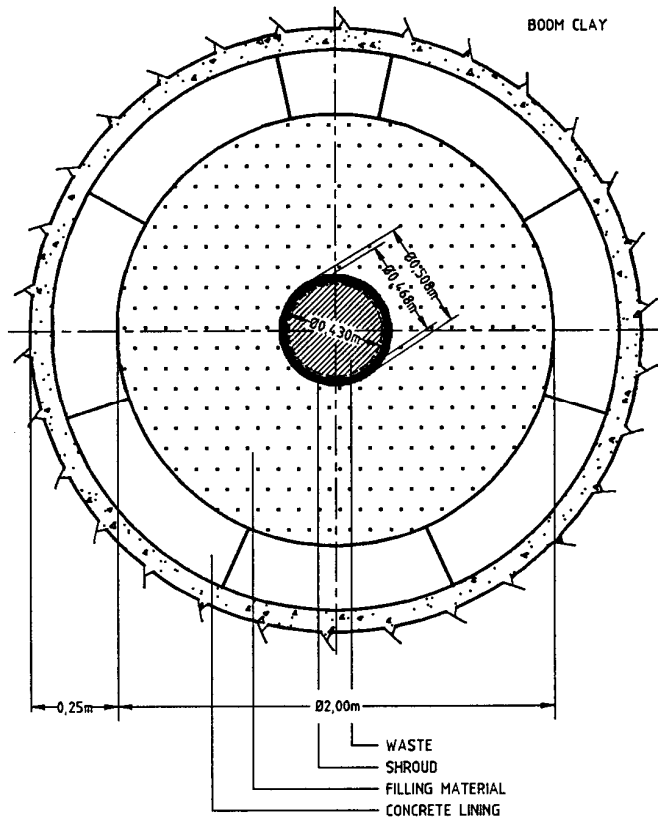

Les pastilles, les déchets eux-mêmes, sont d'abord rendus insolubles et sont coulés dans une matrice de verre, avant d'être coulés dans le béton. Chaque pastille pèse typiquement une demi-tonne.

- Argile
- Revêtement de la galerie
- Matériau de colmatage
- Tube métallique
- Colis
- Déchets radioactifs

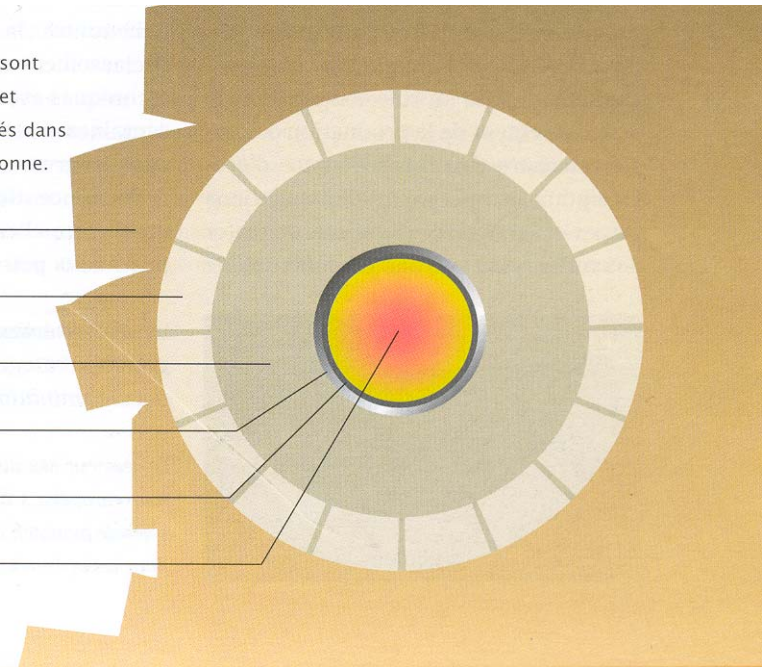

This scheme will be used for heat emitting waste. Between the lining and container (shroud). The gallery is lined (concrete ring) to ensure stability and the space between the shroud and the lining will be filled by an impermeable material



# An overview of the underground research laboratory in Mol

## UNDERGROUND RESEARCH FACILITY

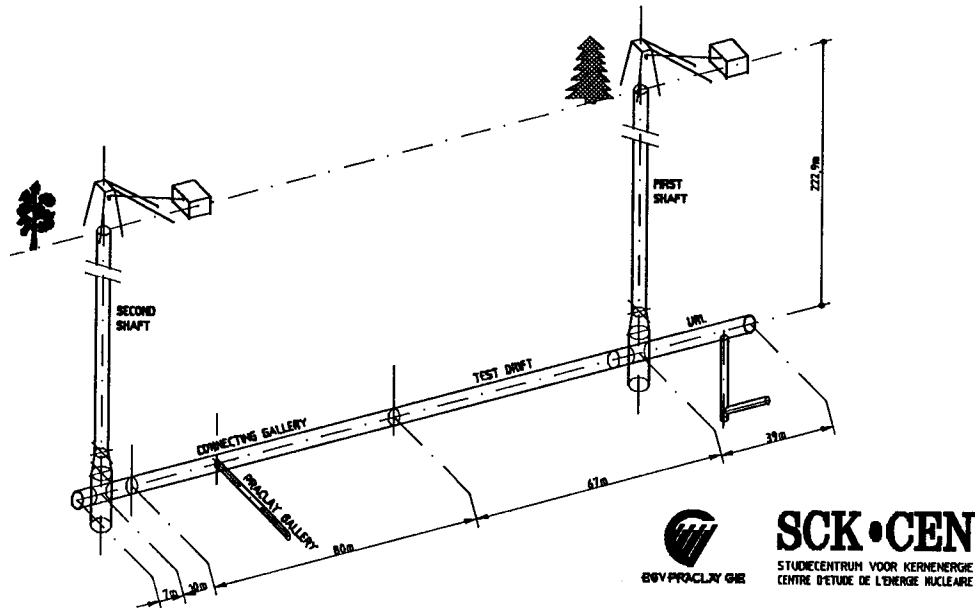

Concept of the URL



View of the first shaft

## Developing a mine-like repository

Accessing the geological formations in depth using mine-like methods can be performed in two ways:

- By sinking a vertical or inclined shaft from surface. This structure needs be a straight line and equipped with guides for the use of cages (elevators used for man and equipments transport, a material handling) or skips (buckets or containers used to handle broken rocks).
- By digging a decline (inclined gallery) that can be used by road vehicles to access the deep galleries. Conveyor belts can be used as well to move broken material. The method is cheaper but is used mainly for shallow workings.

**From the access structures (shaft or decline) one needs to develop horizontal galleries to access the targeted areas.**

# General scheme of an underground mine using a vertical shaft

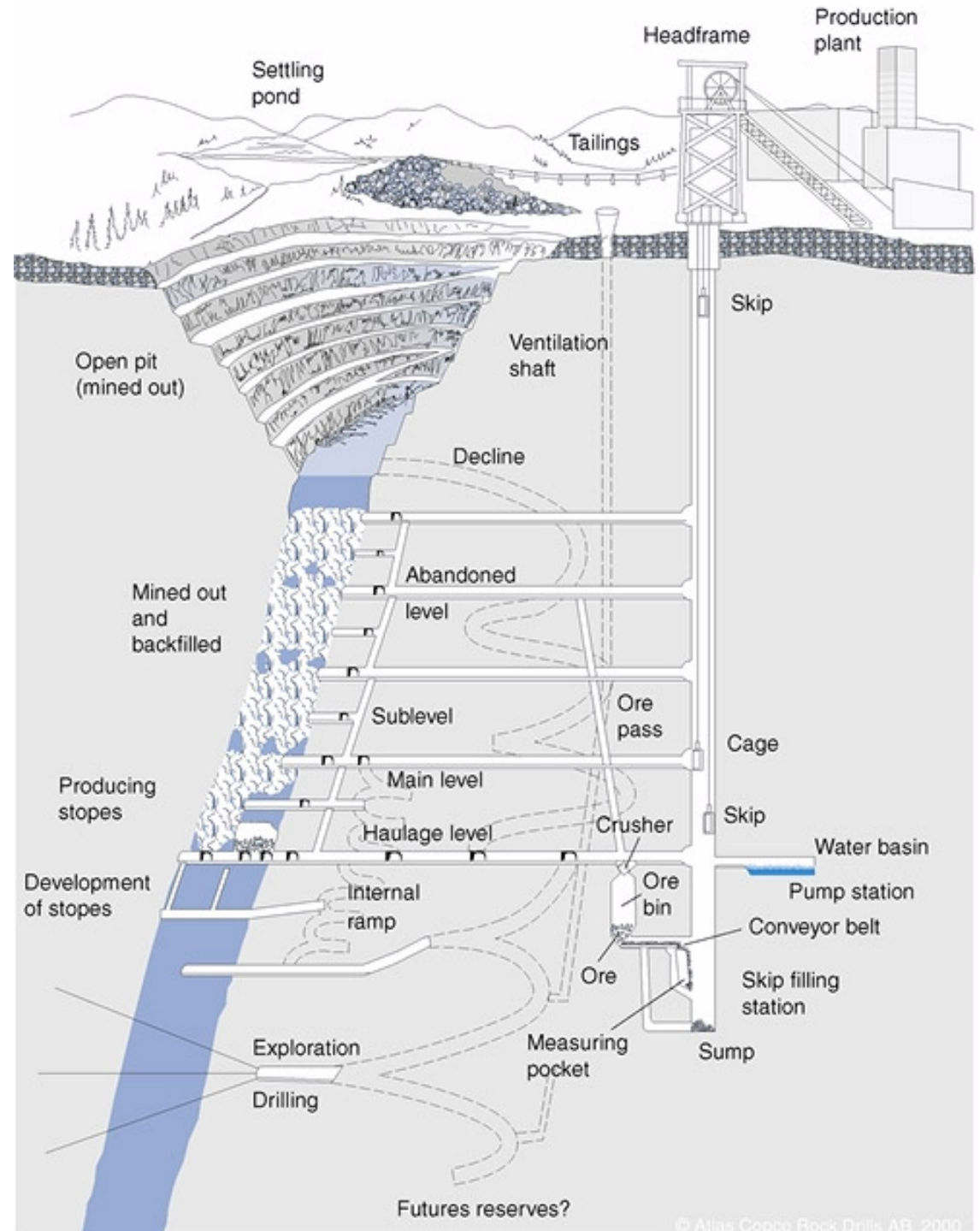

# Men and equipment transport in a shaft



# The use of a decline to access underground

Conveyor belt

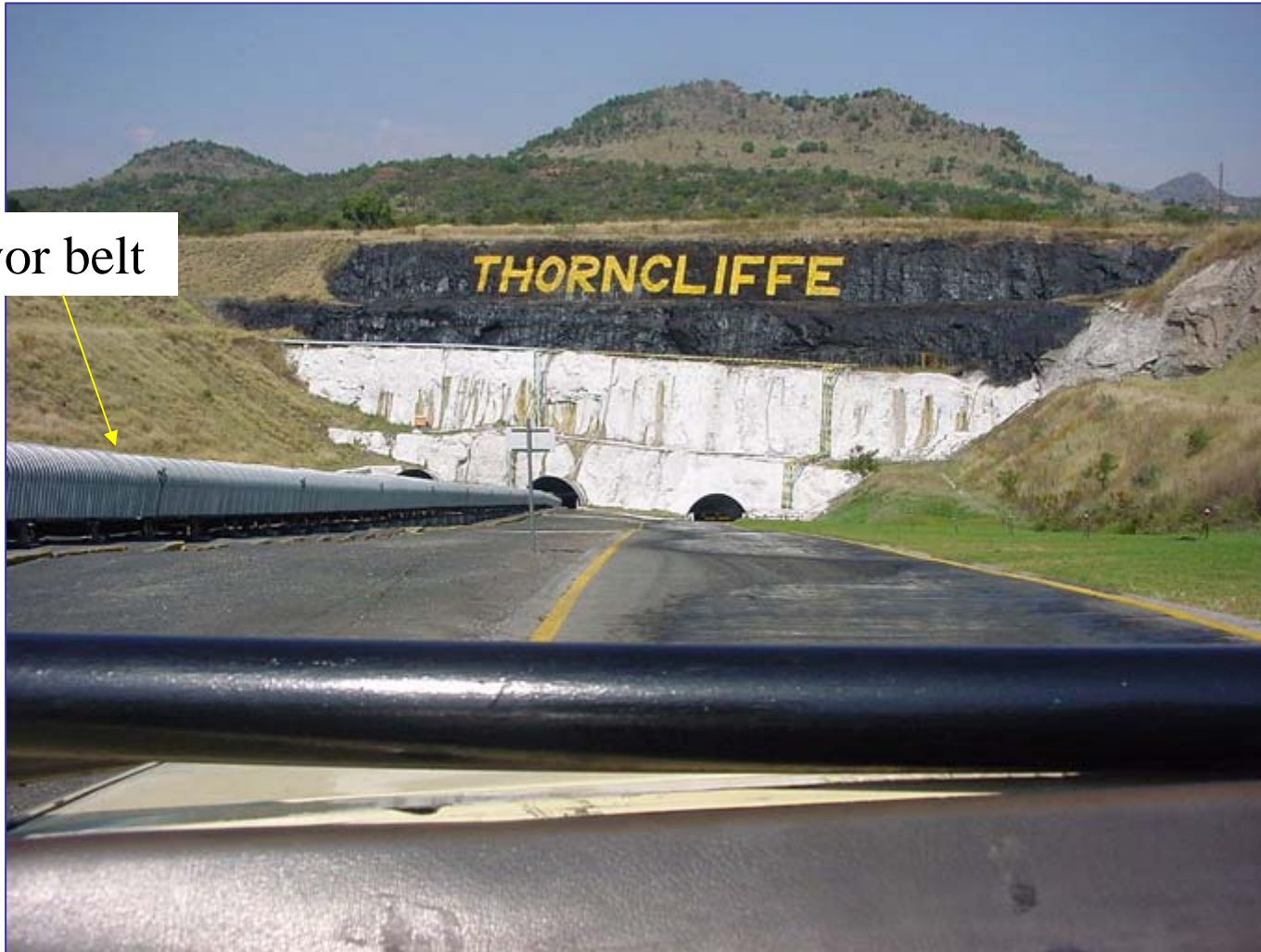

# Men and equipment transport in the decline



# Digging method

Depends on the mechanical properties of the rock and hydrological conditions:

- Hard rocks - no water flow : use of the classical method of drilling and blasting; Tunnel Boring Machines (TBM) possible only for long distances.
- Hard rocks - water flow: use of cement or another chemical to fill the cracks and faults before drilling and blasting; TBM with air or mud confinement.
- Soft rocks - no water flow: use of open shields to dig with machines (back hoe, pneumatic or hydraulic hammer, ...);
- Soft rocks - water flow: use of closed shielded machines (Tunnel boring machines with confinement by compressed air, mud pressure or mechanical support). The machine is to be waterproof.

# Drilling and blasting technique – drilling pattern

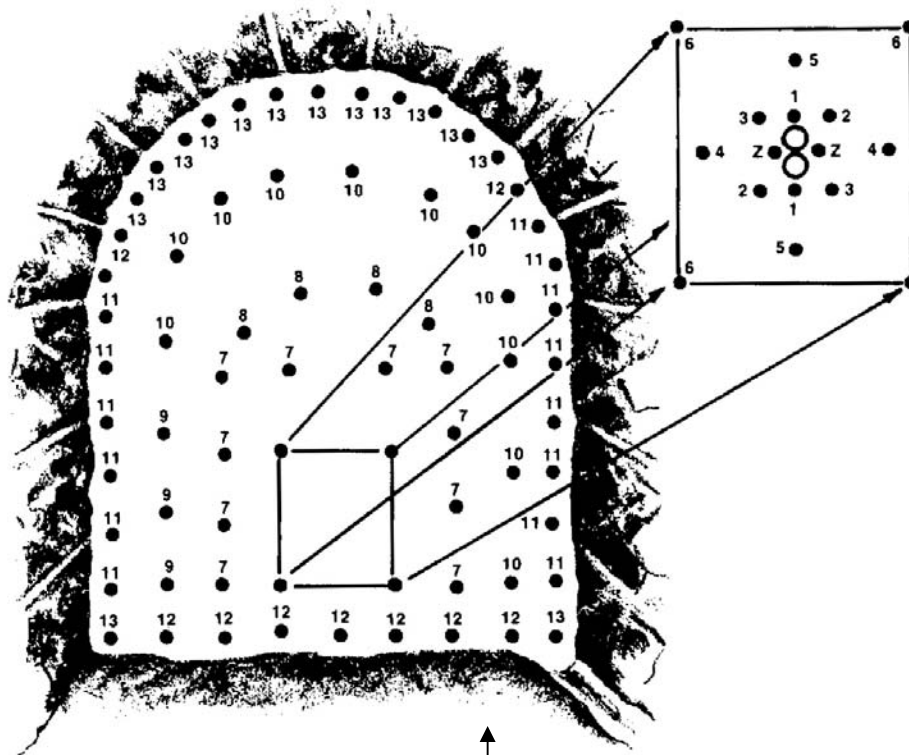

Burn cut

Conical or pyramidal cut

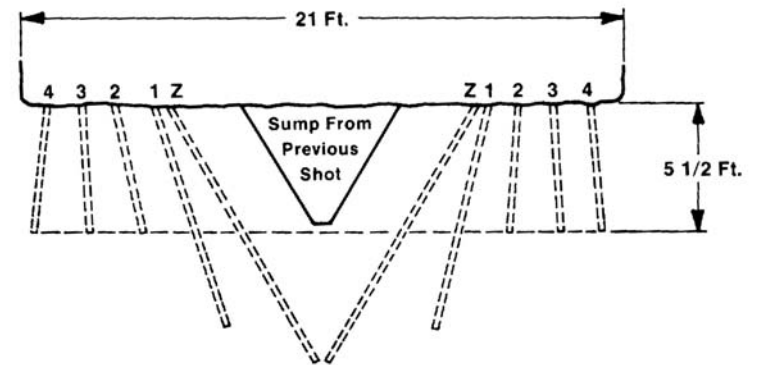
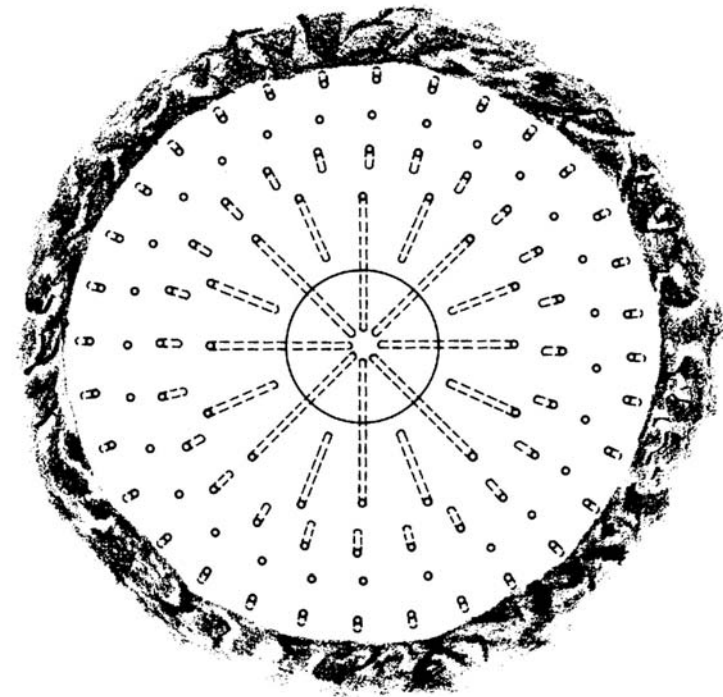



# Working cycle in the drill and blast method

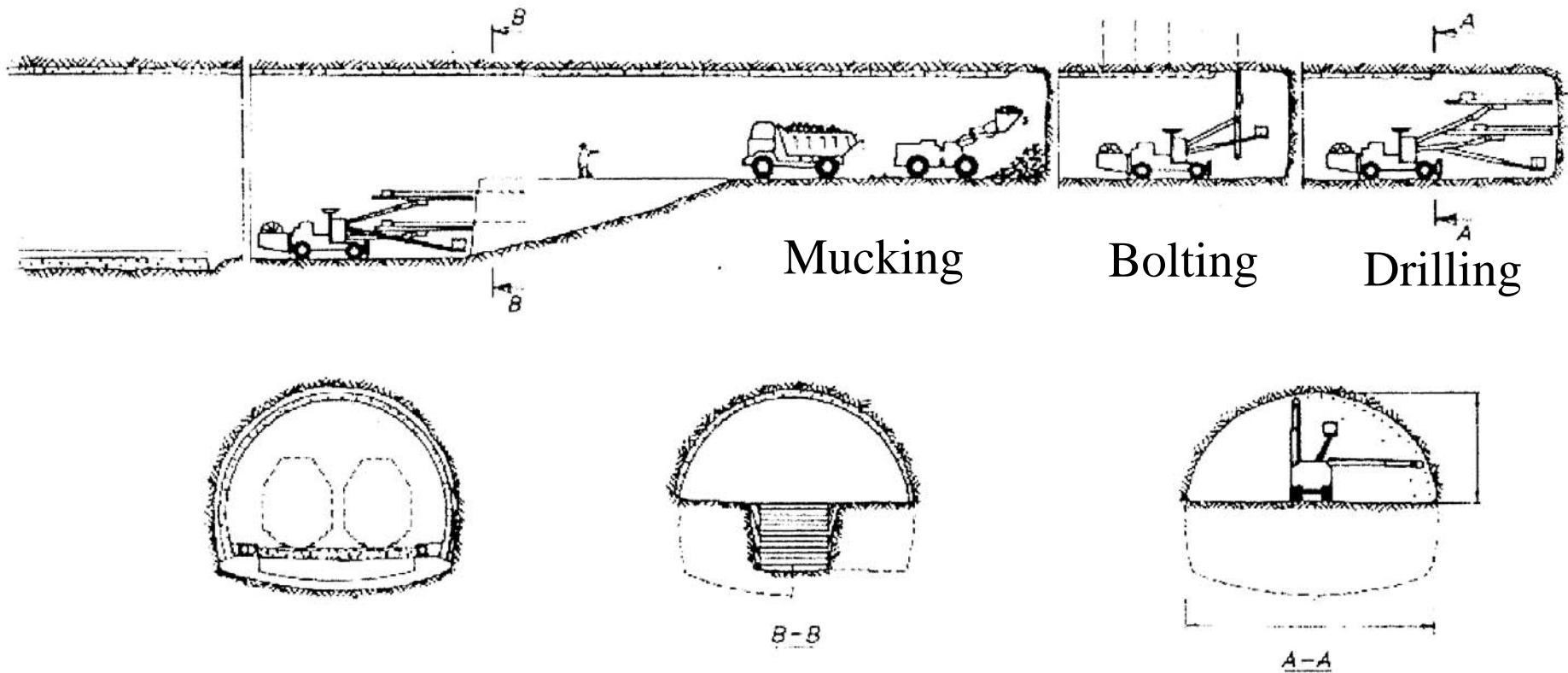

# Working cycle – use of tracks

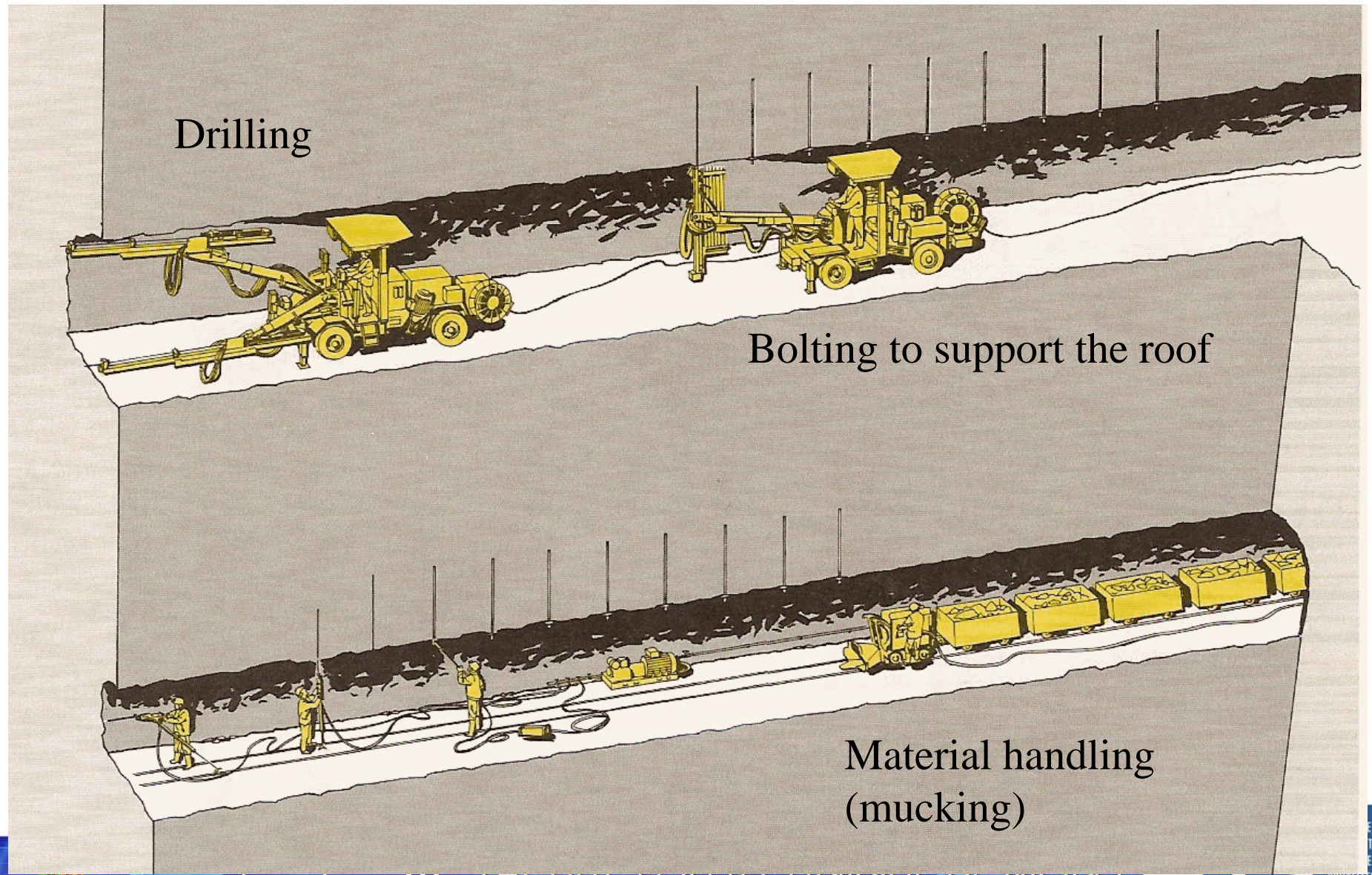

# Drilling and bolting: Use of jumbo drills

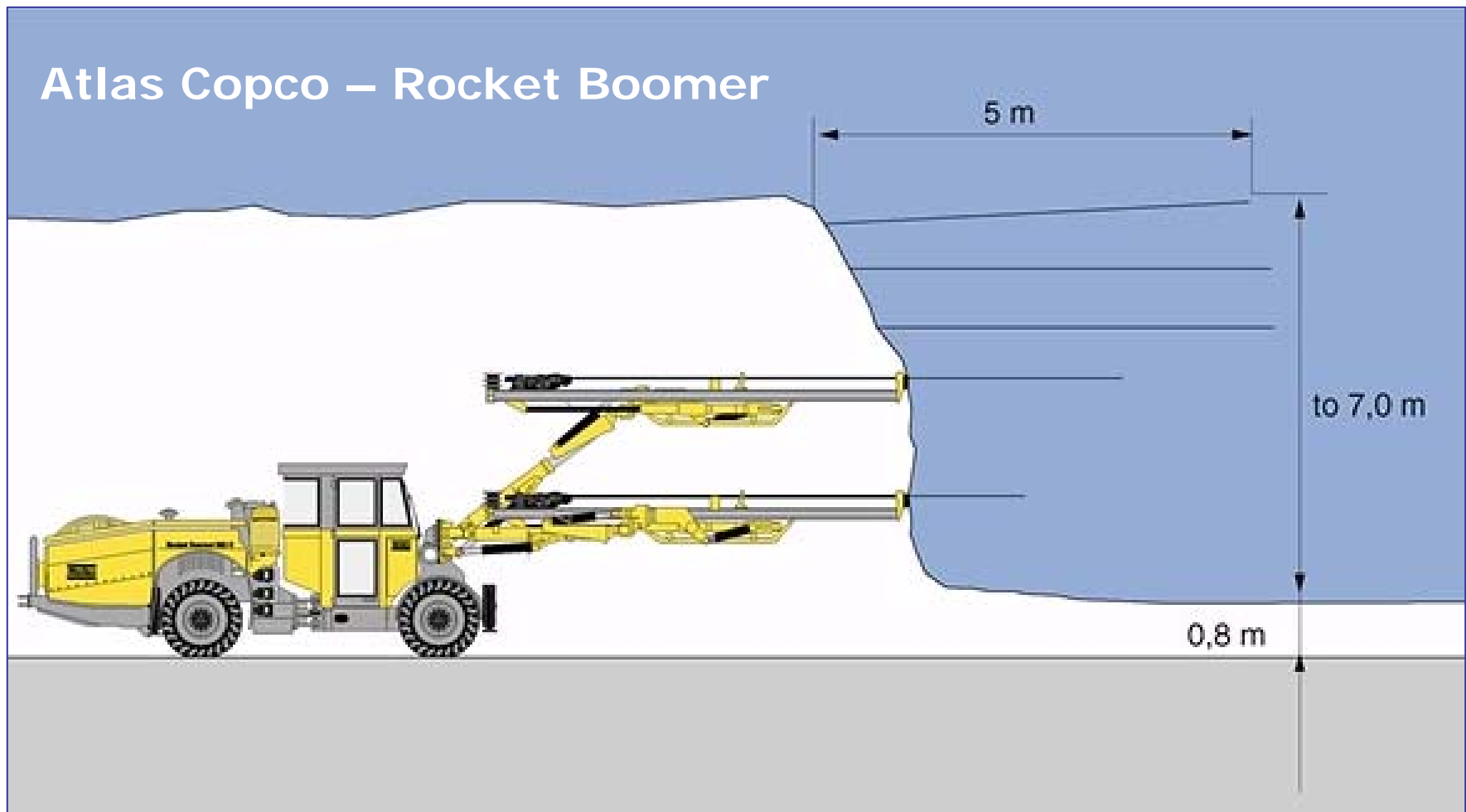

## Mucking operations: debris evacuation



FRONT LOADER AND TRANSPORT VEHICLES

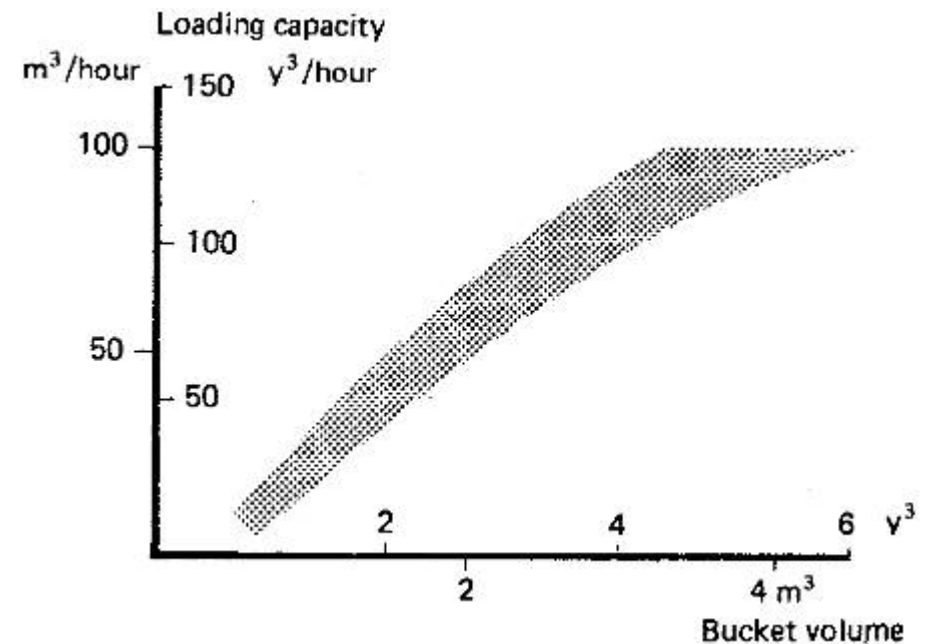

The blasted material is loaded by front loader machines and put in underground trucks. Suitable for great distances

# Use of Load Hall Dump (LHD) machines

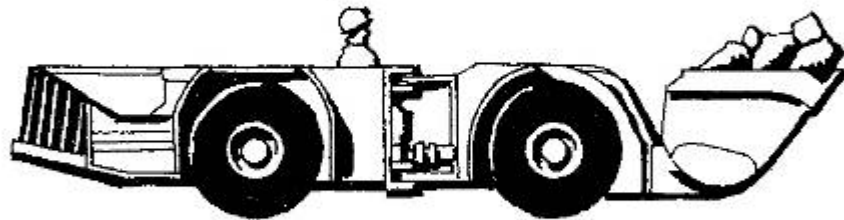

DIESEL DRIVEN LHD LOADER

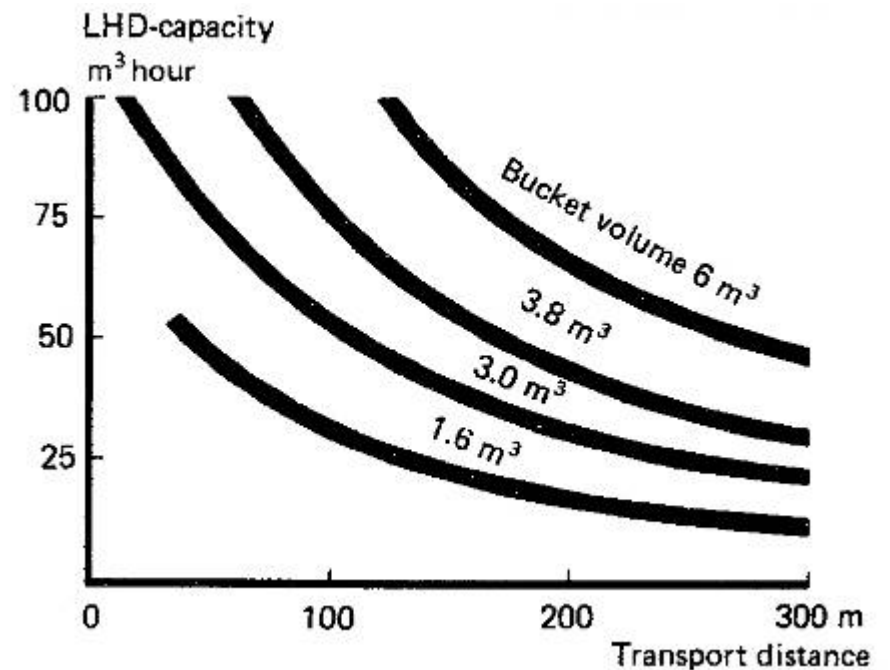

The machine load and move the material to the tipping point. More suitable for short distances.

## Mechanised digging in soft rocks by use of continuous miners

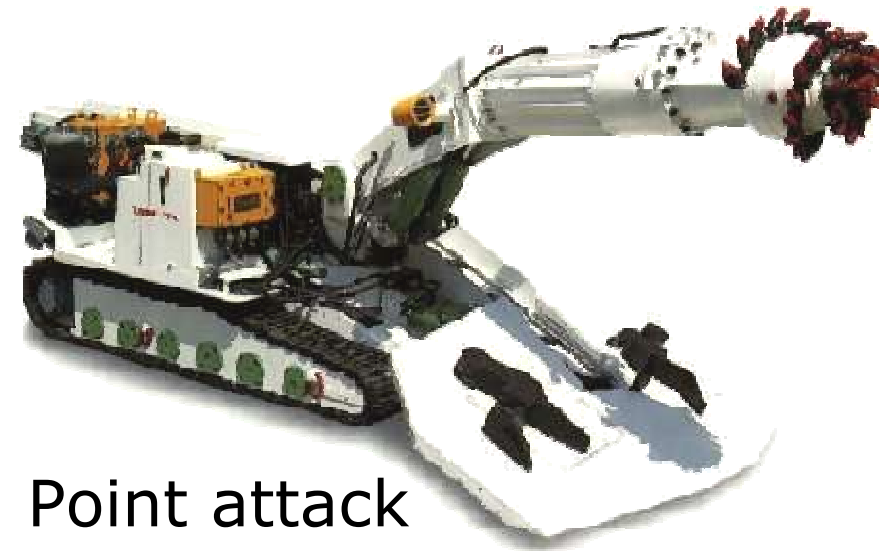

The machine is equipped by rotating head with spikes to cut the rock. Use only in soft to medium resistant grounds. This type of machine can be used for any cross sectional shape of the tunnel (circular, squared, ...). The abrasiveness of the rock is to be assessed to address wear problems.

# Use of shielded machines in very soft non aquifer grounds

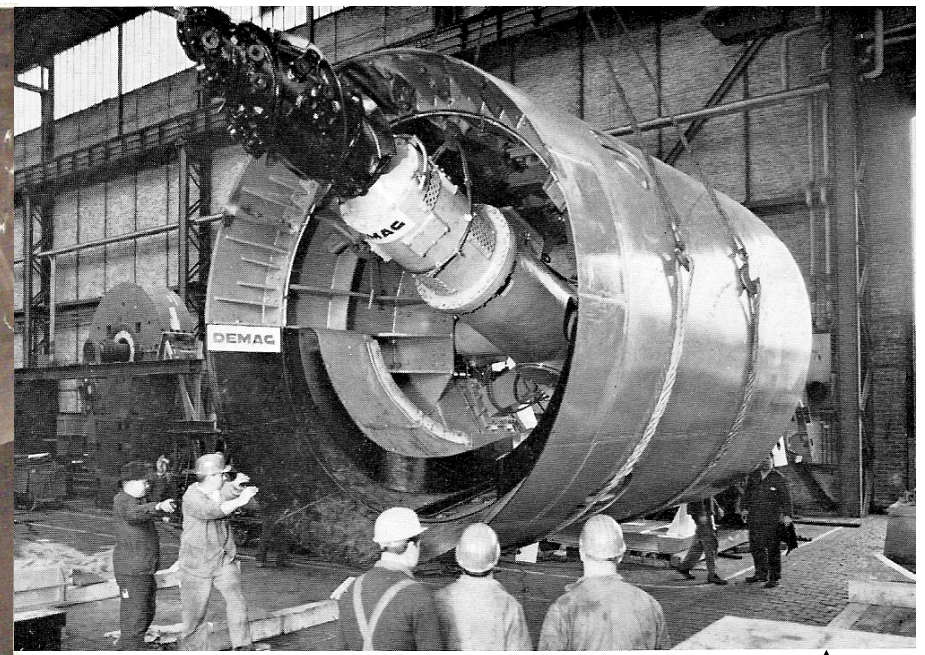
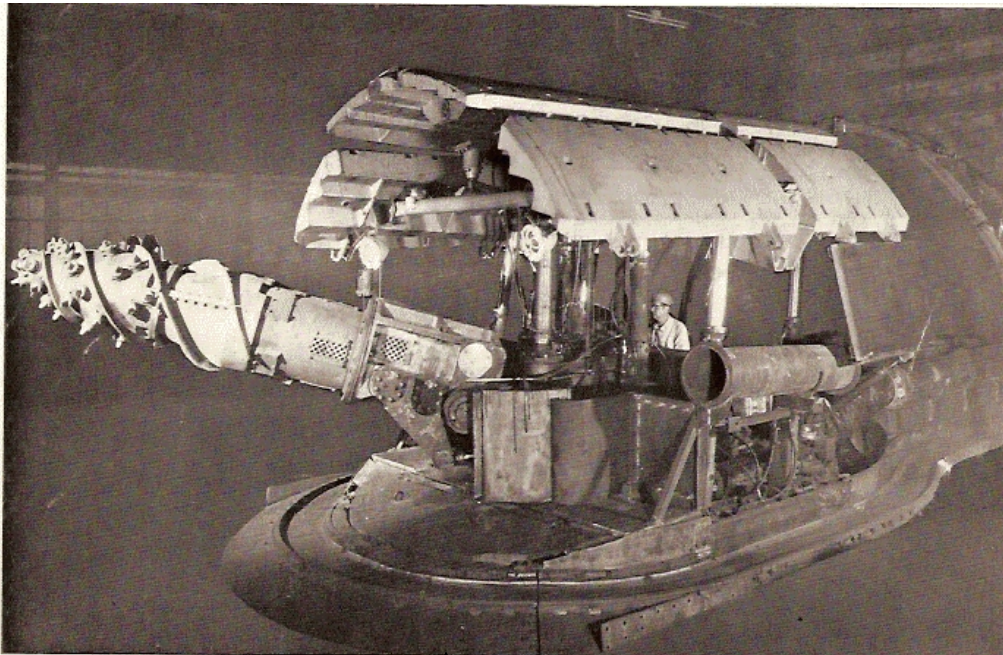

Radial attack  
Machine with a  
roof support

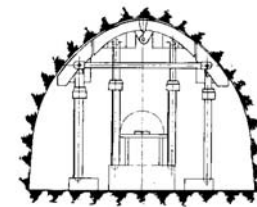
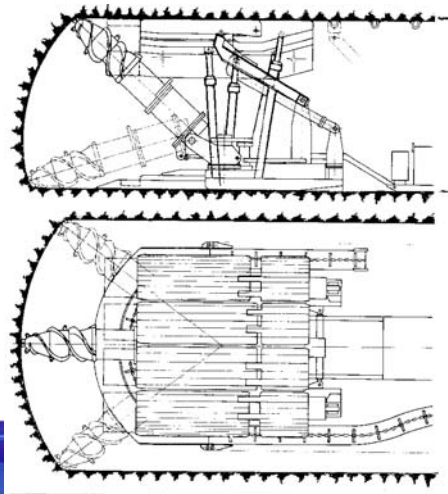

Schneidbereich:  
Streckenbreite: 4,90 - 6,20 m  
Streckenhöhe: 2,20 - 4,30 m

A machine  
equipped with  
a circular  
shield

# Use of a shielded TBM for digging the junction gallery in the underground NW repository laboratory in Mol (Belgium)





# Full face TBM for competent ground

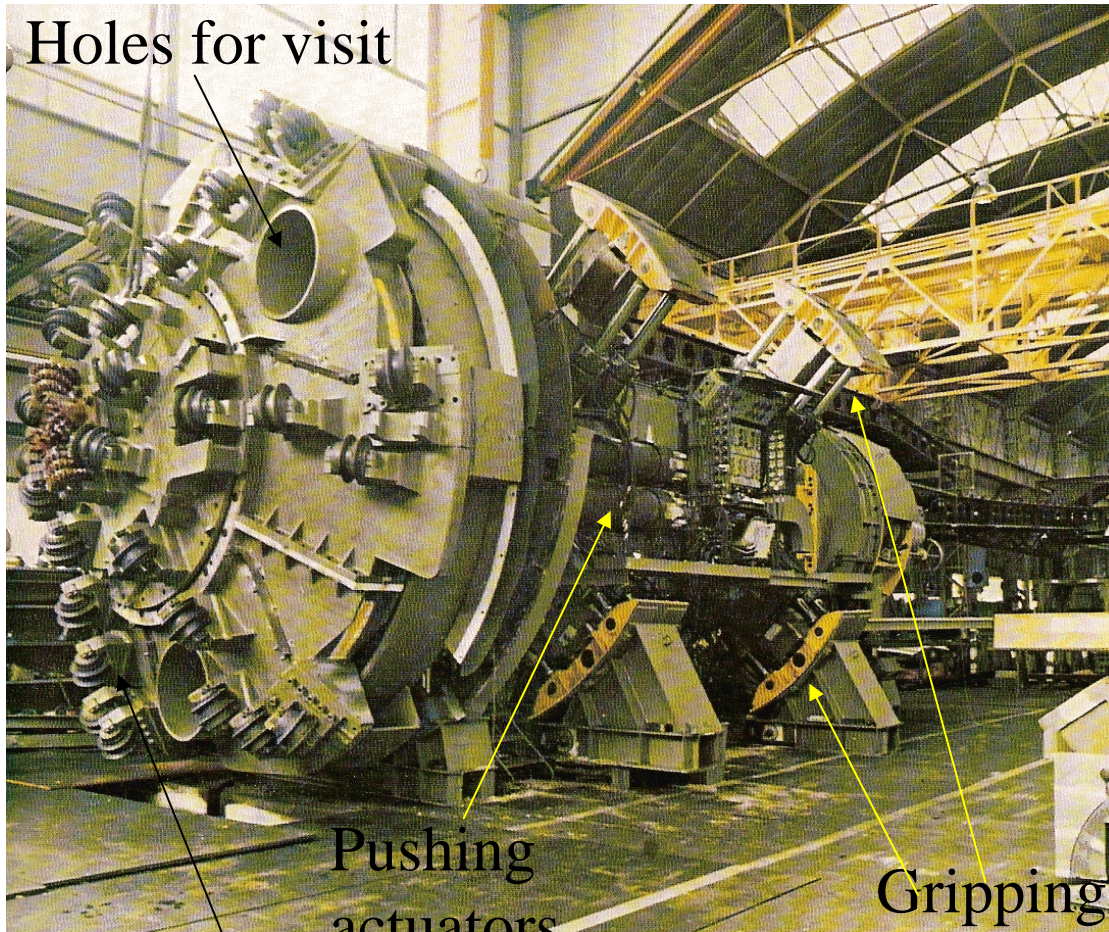

Holes for visit

Pushing  
actuators

Gripping  
supports

Cutting tools mounted on  
the head

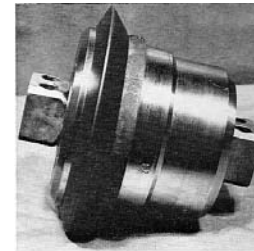

Fig. 22 Disk cutter

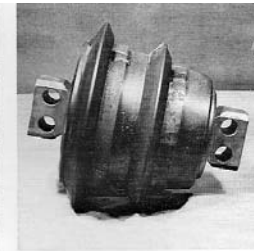

Fig. 23 2-disk cutter

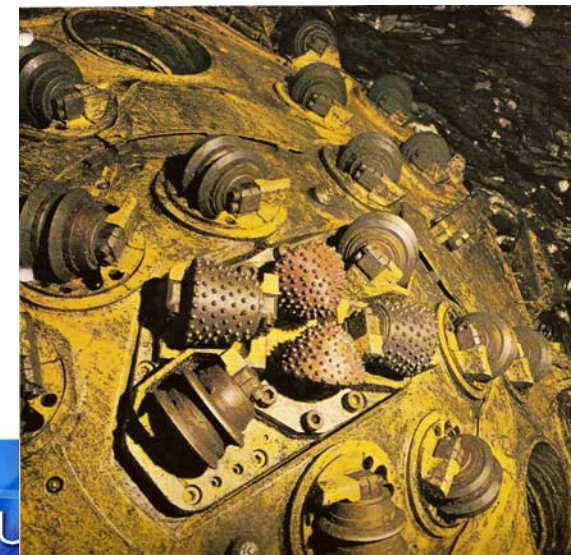

Fig. 24 Carbide insert cutter



Fig. 25 Toothed cutter

Tools: disks, rolling cones  
with milled teeth or inserts



The TBM (Tunnel Boring Machine) of full face type is composed by the boring machine itself followed by a trail.

The boring machine has a rotating head to cut circular tunnels by means of cutting tools that have to be chosen according to the mechanical properties of the ground (strength and abrasiveness). The machine also has its own advancing system by use of gripping and pushing actuators. A mucking system is also included to remove the broken material from the face to the rear by a conveyer.

The Trail brings all the technical equipments (compressor, support erecting systems, ...).

## Drill and blast in shaft sinking

The working method is cyclic as for horizontal openings.

Drilling is performed by means of hand operated pneumatic or hydraulic hammers.

Sometimes the hammer can be secured on an upper platform and the drilling rods are of 2 to 3 m long. A mechanical pushing device can also be used.

The explosive is then charged and the face blasted.

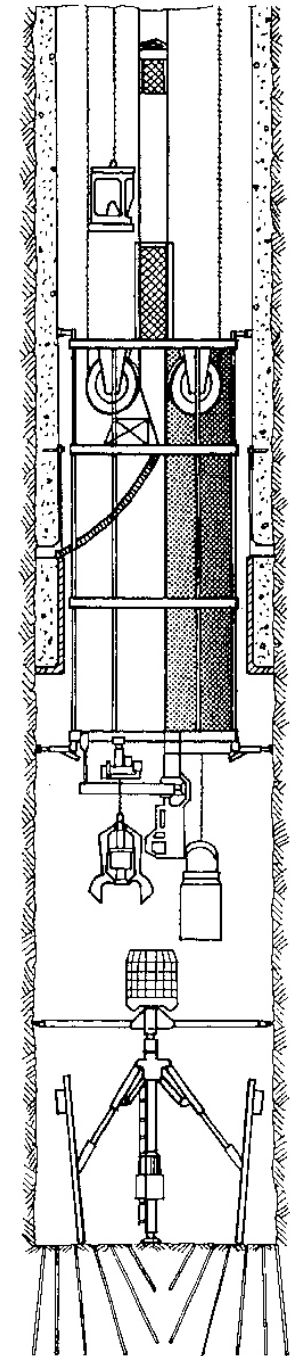

# Mucking for shaft

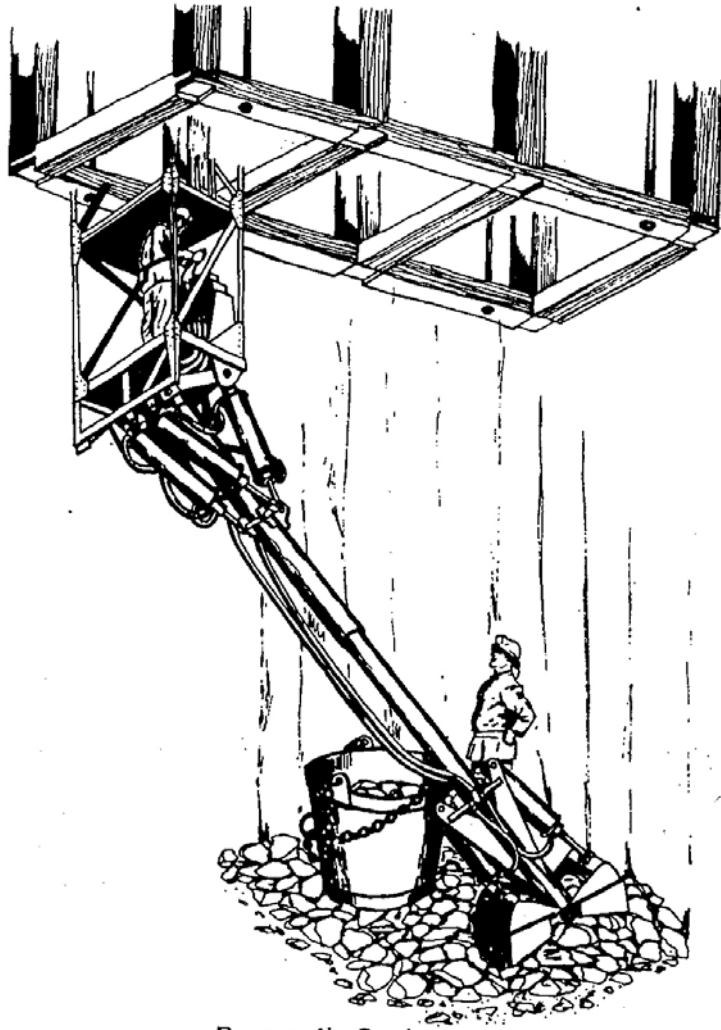

Pneumatic Cryderman mucker.



# Use of freezing method in soft and aquifer formations

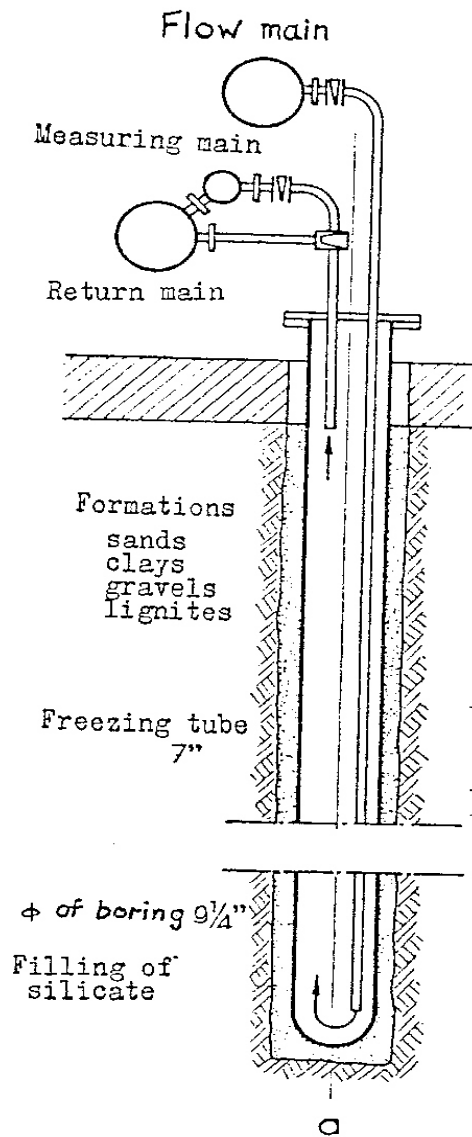

Use of wells and freezing pipes

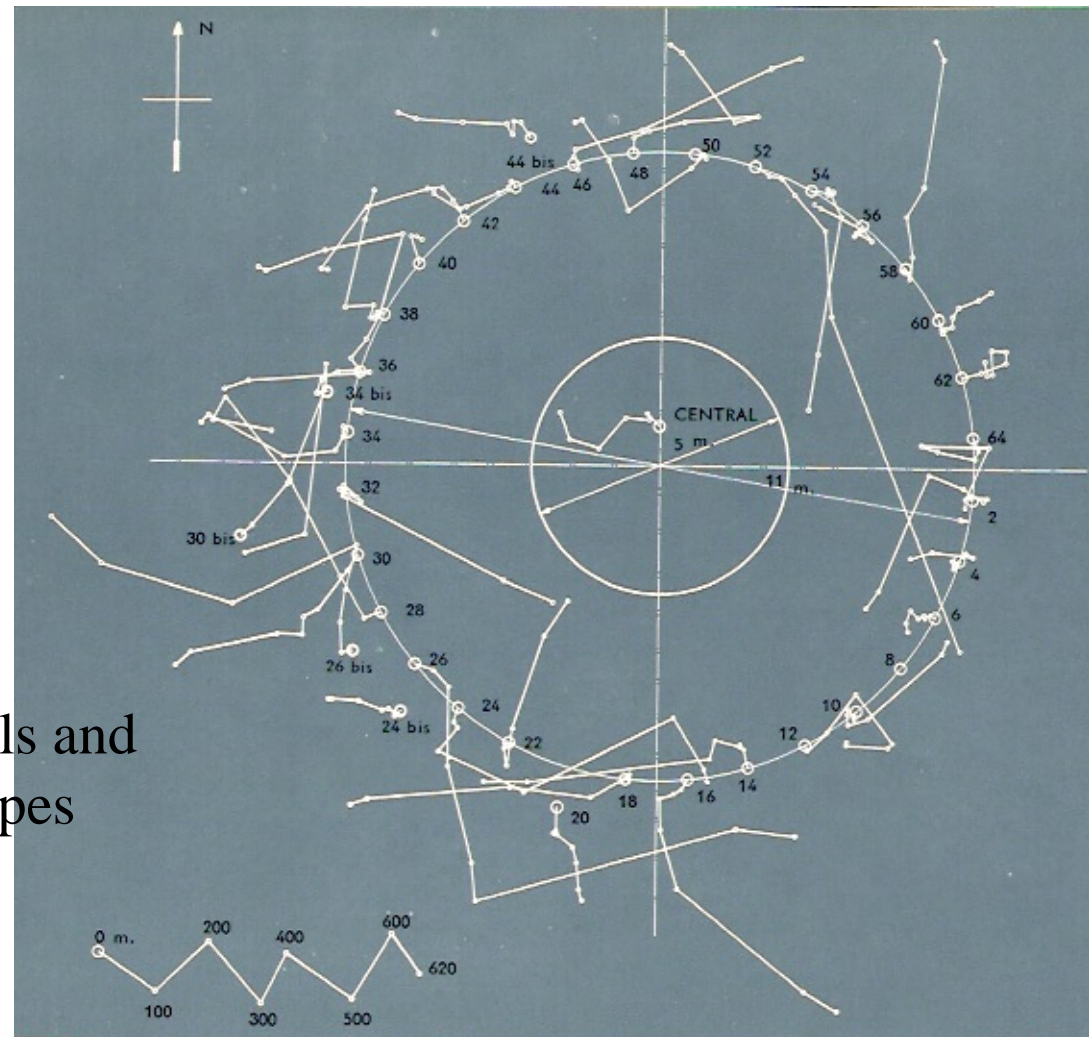

# Sinking the second shaft in Mol



# Mechanical shaft sinking

Use of great diameter boring machines. During the sinking the wall support is given by a mud hydrostatic pressure.

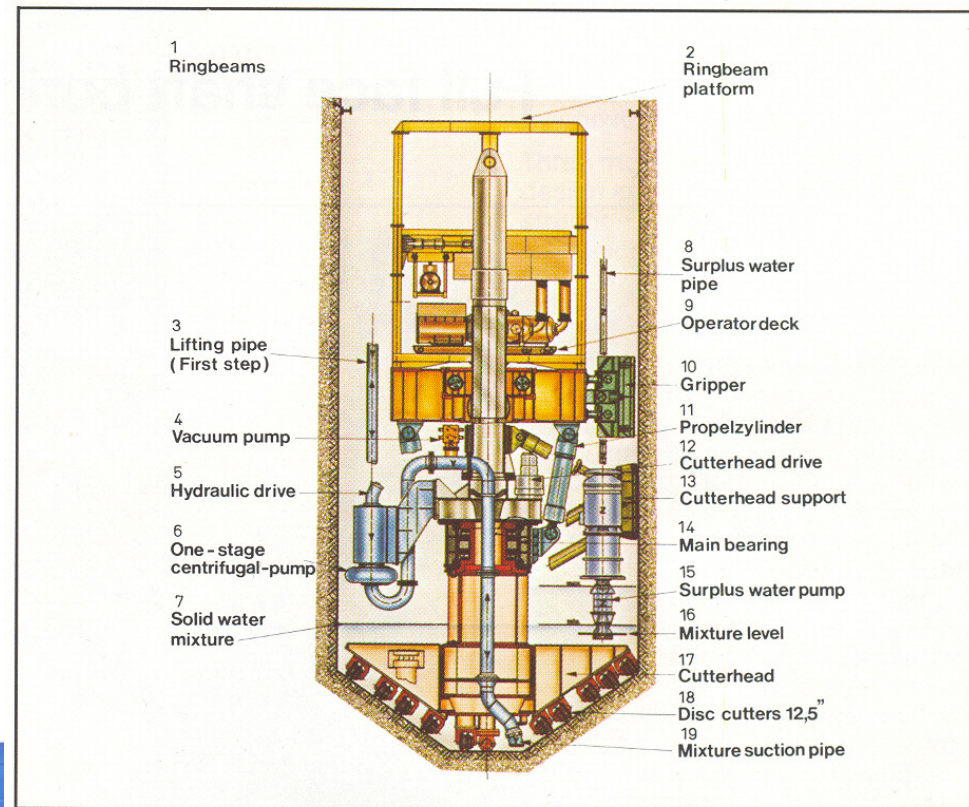
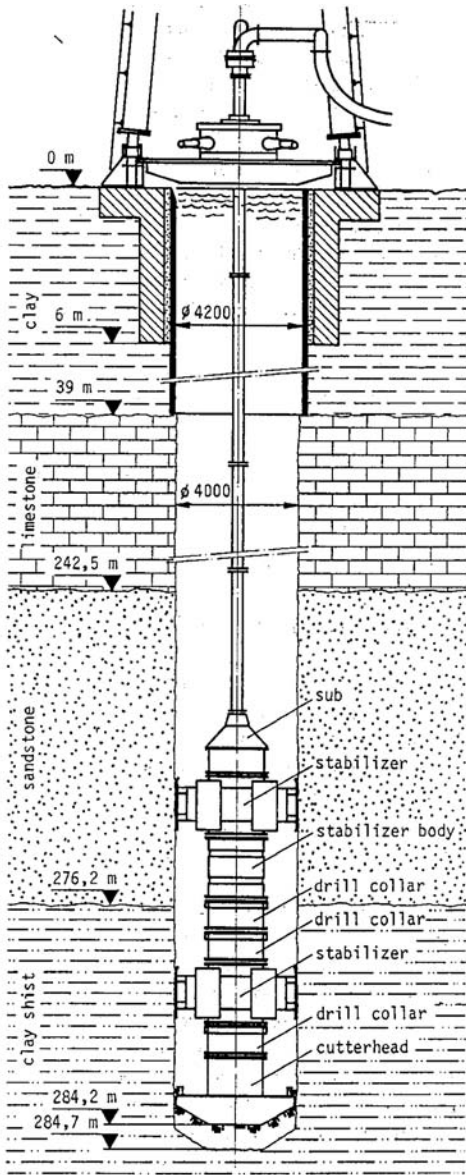
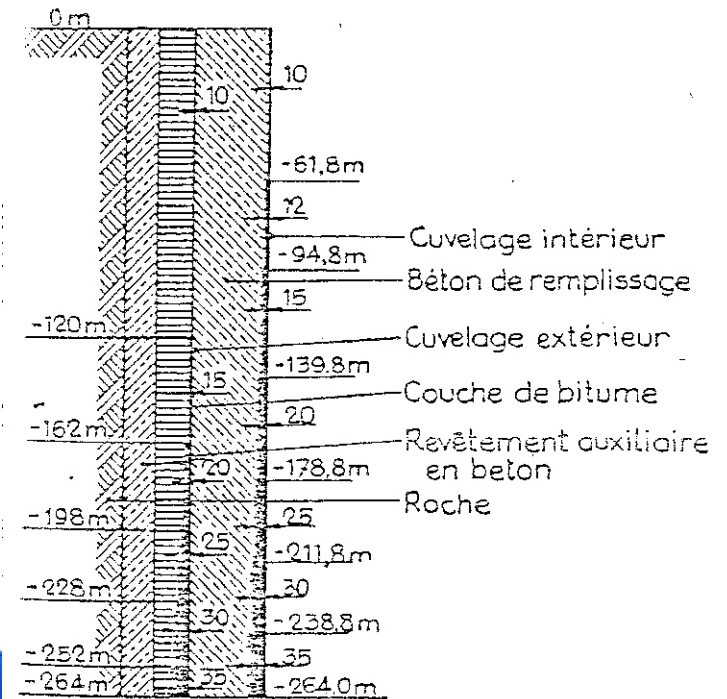
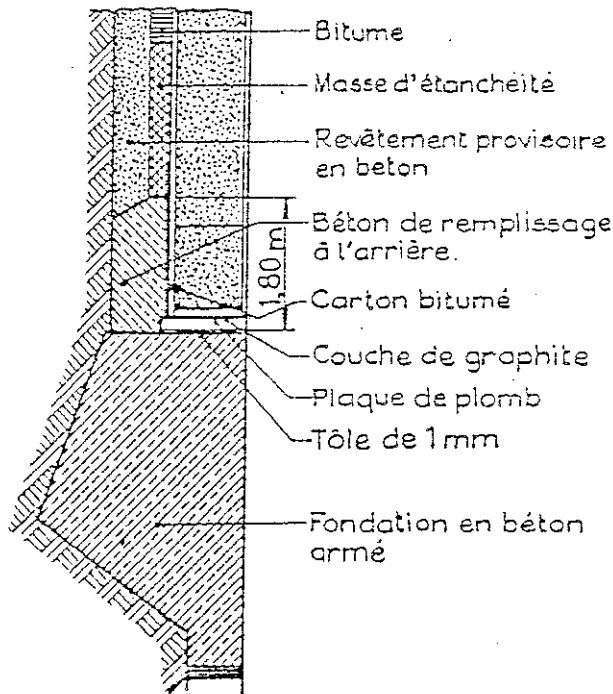
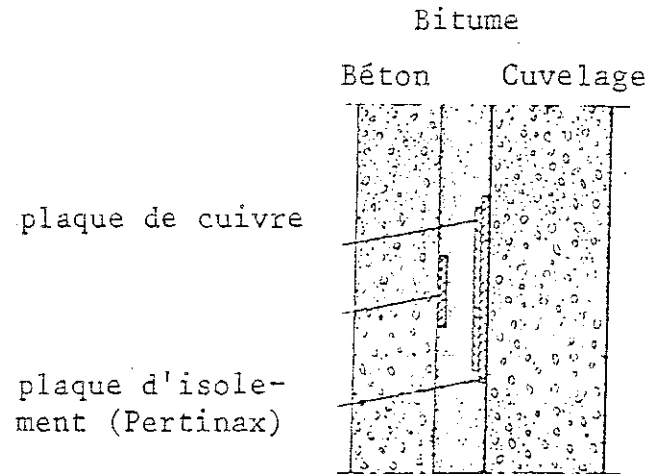
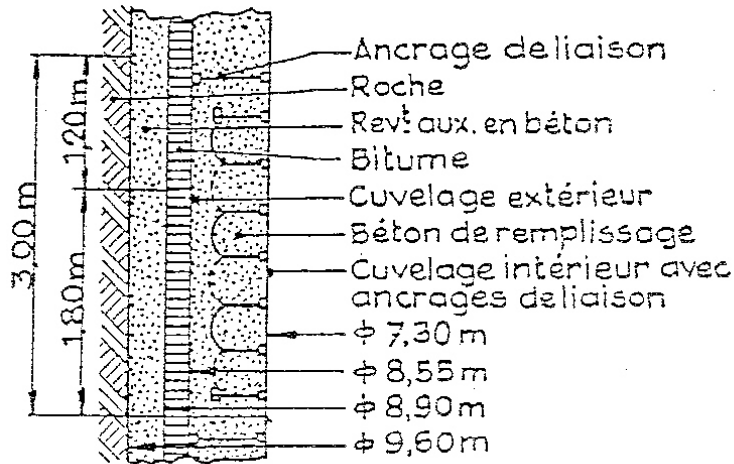

Fig. 1: Modified full face blind shaft borer, Wirth model GSB V 450/510.

# Revêtement définitif du puits





# Supporting the openings

When the rock mass is not competent a suitable support must be provided :

- during the advancement of the face to protect the working area: steel rings, timbers, shotcrete, bolts, etc.
- For a long term control: armed concrete lining.

**One needs analytical and/or numerical modelling to assess the behaviour of the rock mass around the opening (see part II)**

An example of shaft final support

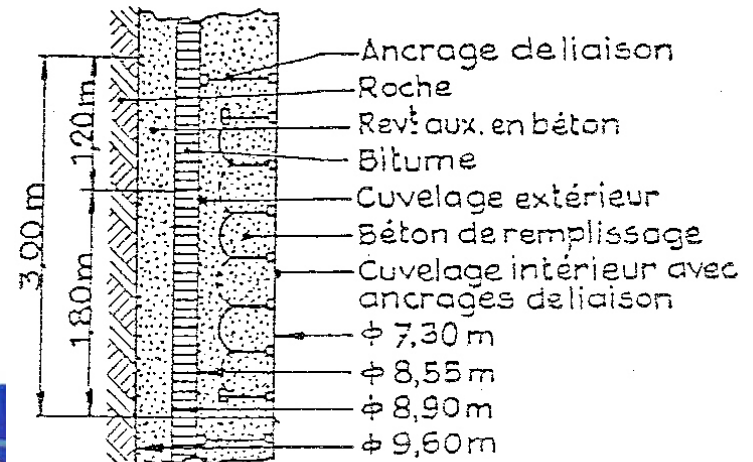

## Examples of overstressed galleries



Production gallery in the Puertollano coal mine in Spain

Collapse of a production gallery in the Cullinan diamond mine in RSA (700 m depth)



# Backfilling the voids to provide support and seal the storage

Use of sand (quarry) or tailings (washing plant) brought from surface by hydraulic transport – needs for water evacuation. The material is highly permeable.

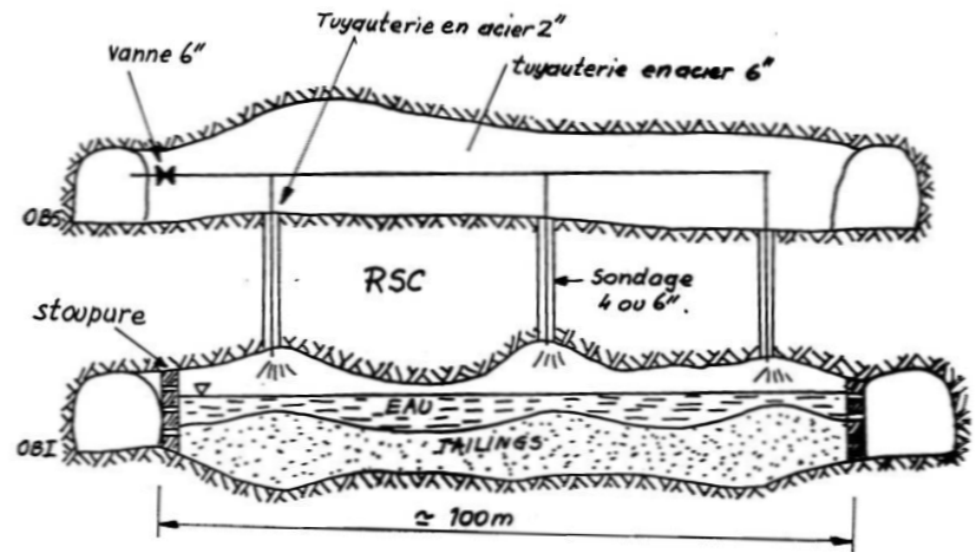
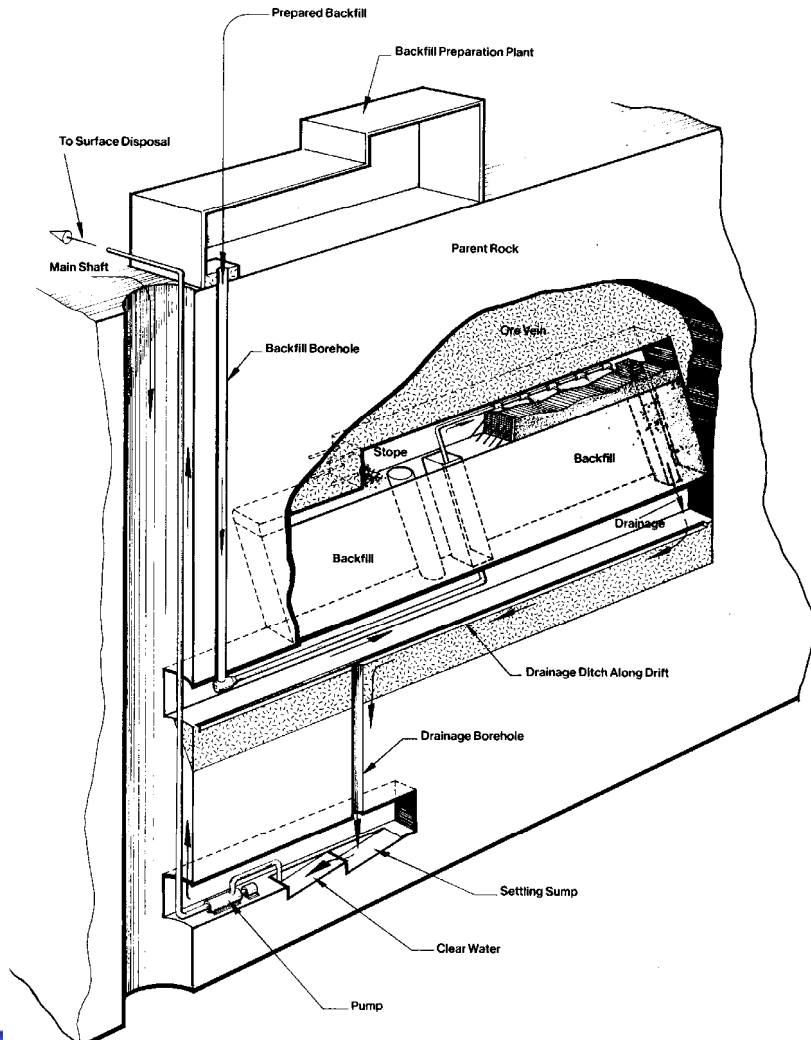

Use of cement prepared in a surface plant and pumped underground.

More compact and less permeable material even if more costly than the non cemented hydraulic backfilling.

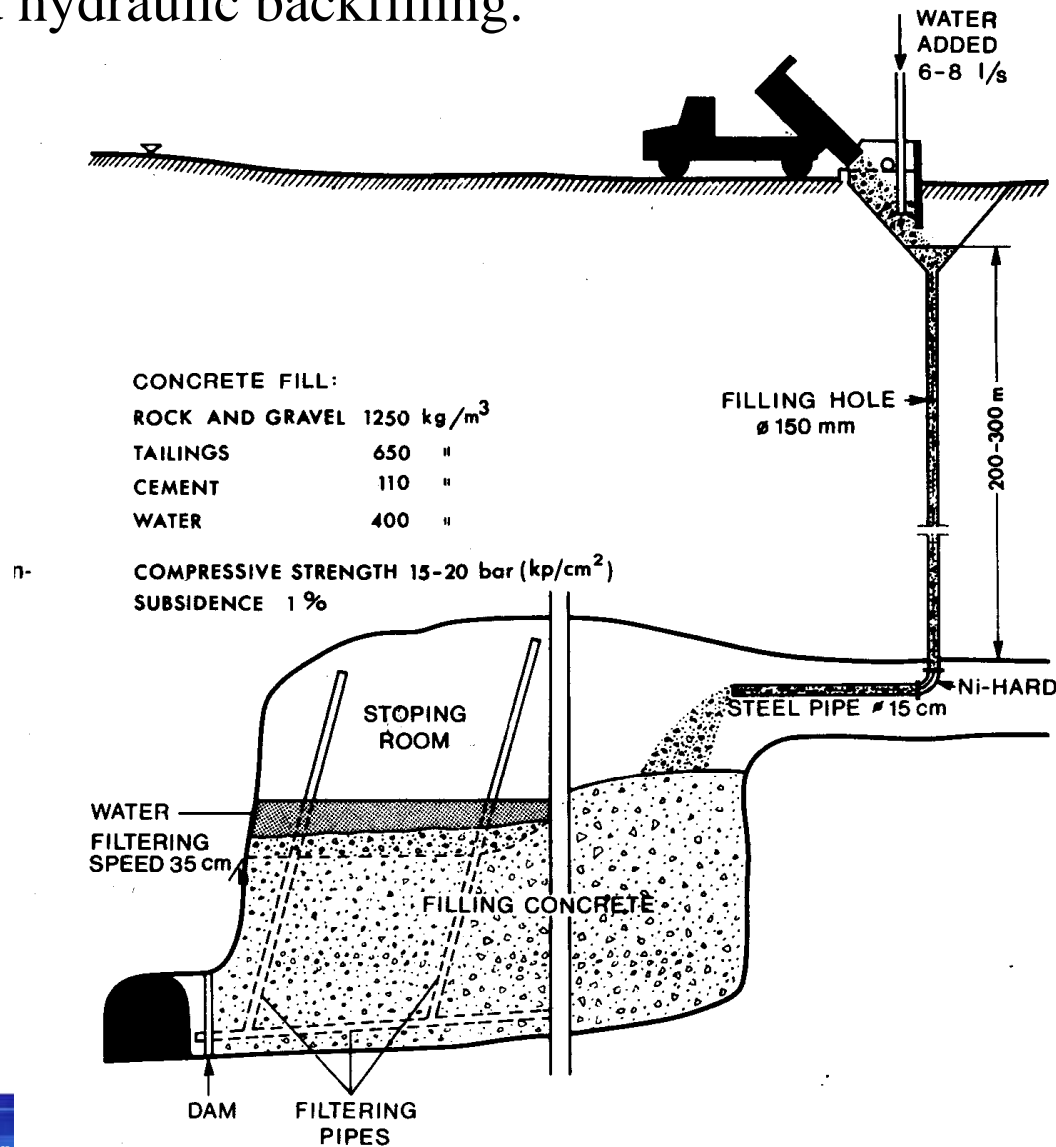

# Content of the presentation

- Introduction
- The geological storage of Nuclear waste
  - General storage method
  - Shaft sinking and gallery digging
- **The Geological storage of Carbon dioxide**
  - General method of storage
  - Drilling and equipping wellbores

# The carbon dioxide material

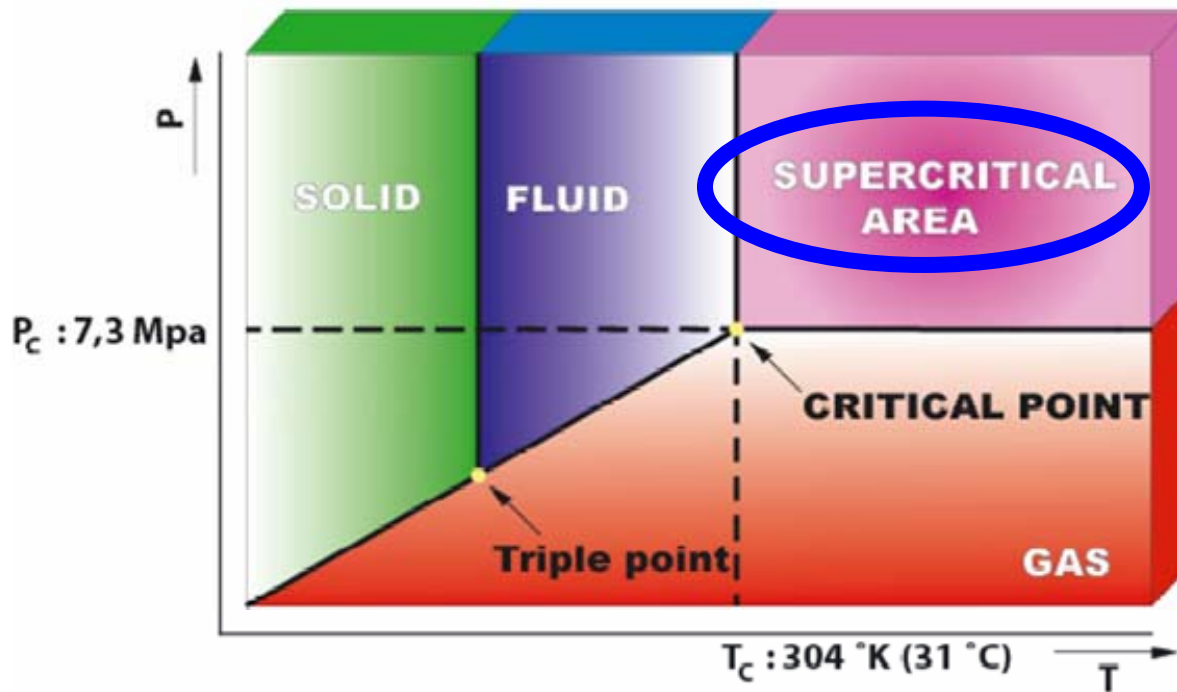

## Transport solutions :

- Pipelines : highly likely
- Tanker (liquid CO<sub>2</sub> > tanker type Natural Gas) : low risks
- Trucks : less likely / small amounts).
  - (2 to 300.000 t/year = maximum ( $\approx 40$  trucks/day !))
- Railways : less likely.

# General storage method

The general storing method consists in injecting the gas preferably in its supercritical state in permeable geological formations (reservoir) situated at high depths (at least 700 to 1000 m).

The targeted reservoir must be covered by cap rock formations exhibiting very low permeability and also providing a lateral seal of the reservoir.

The reservoir is accessed by means of deep drilling technologies and preferably the ones used in the petroleum field.

# The geological storage concept

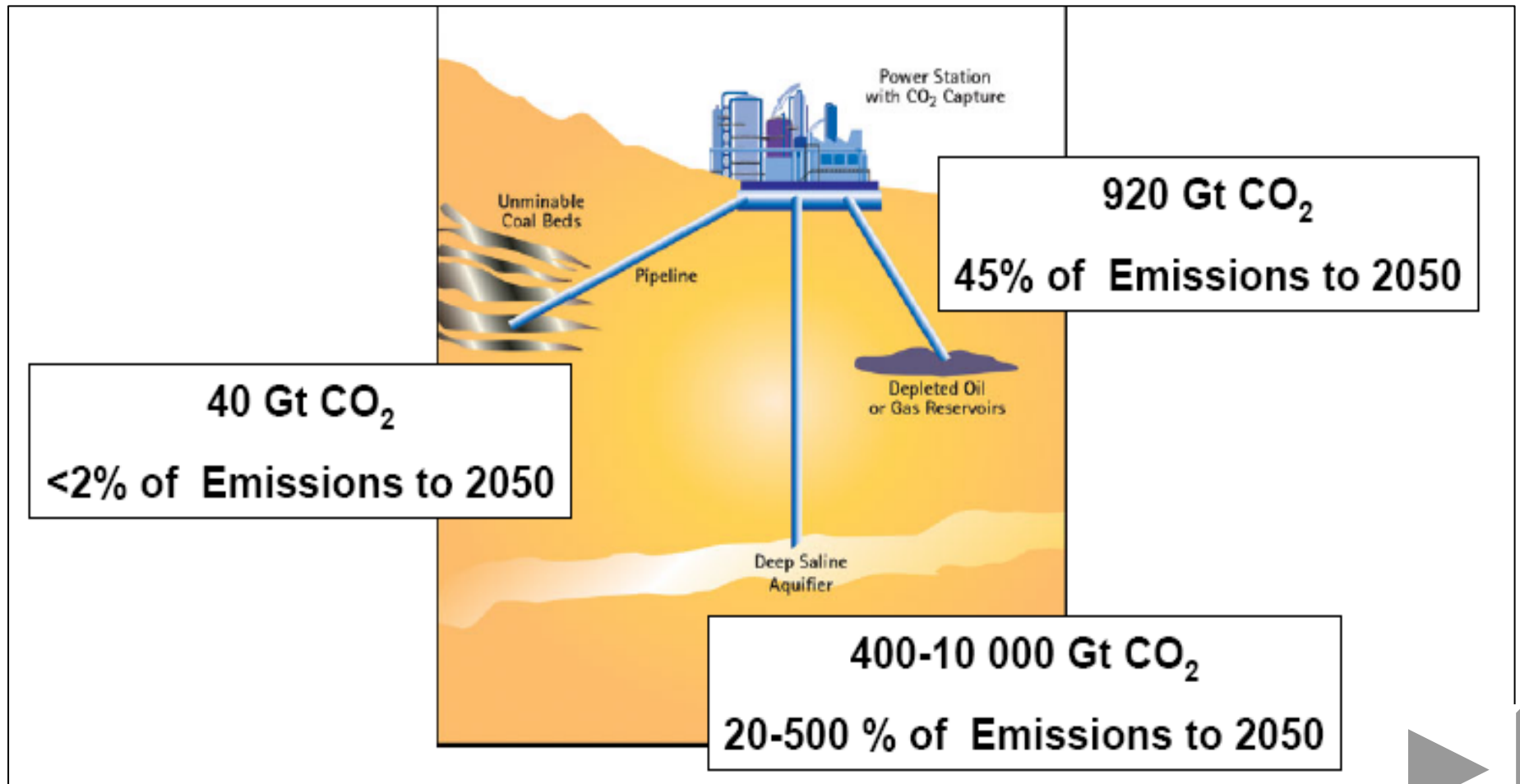

Source : IEA



# Storing in depleted petroleum reservoir (typical traps)

Anticline

Fault

Salt dome

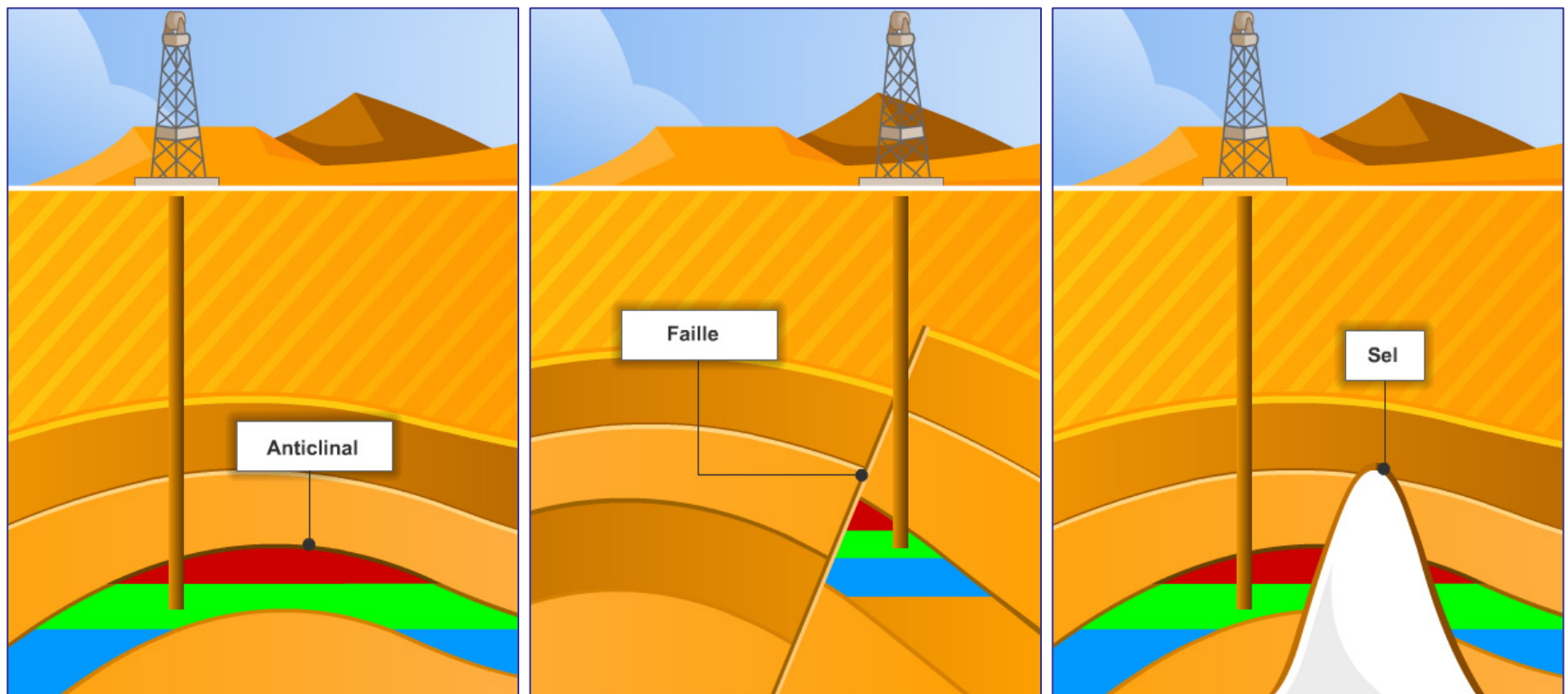

# Using CO2 pressure to recover oil



**EOR**  
(enhanced oil recovery)

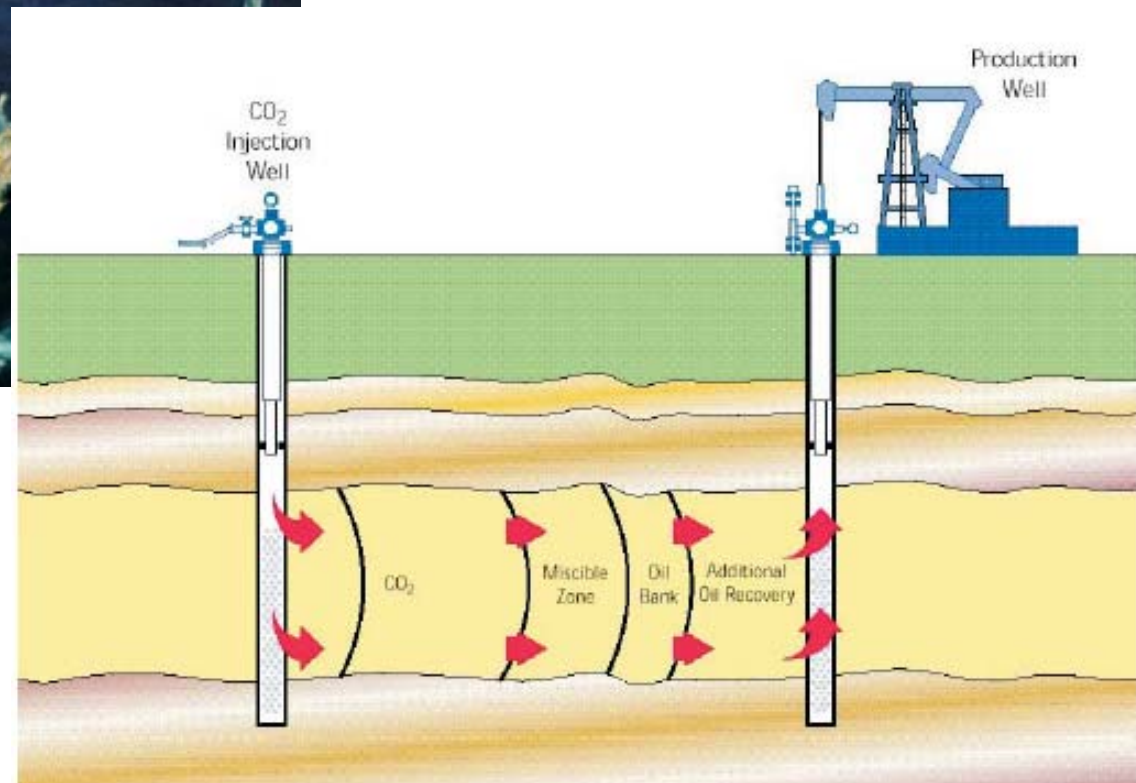



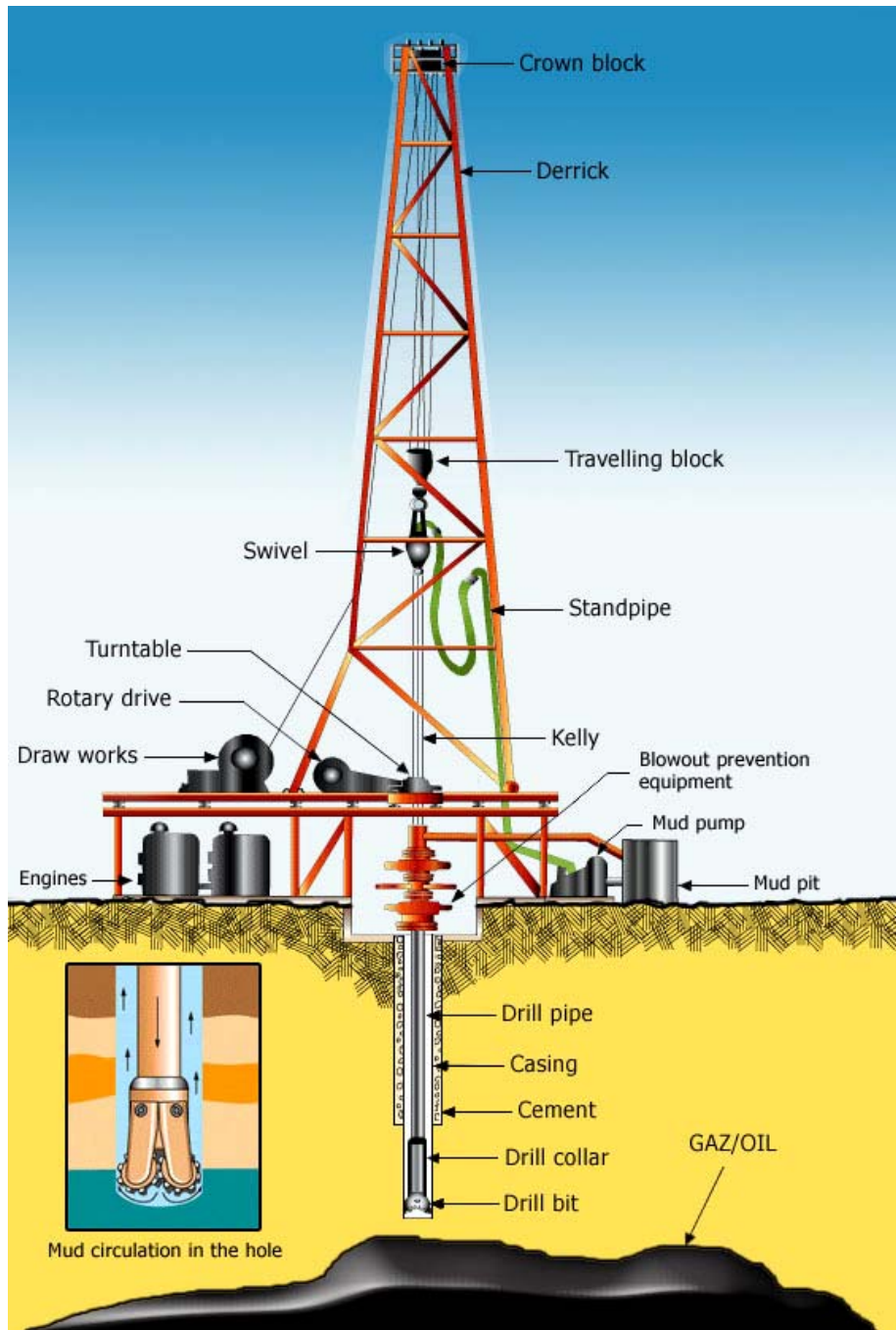

## Deep drilling technology to access reservoirs

- ❑ On-shore or off-shore
- ❑ Components of the rig :
  - Derrick
  - Drilling bit
  - Instrumentation
  - Drill string (pipes, drill collars, ...)
  - Rotary drive
  - Kelly
  - Drilling mud
  - ...

# Drilling rigs and operations



Off shore

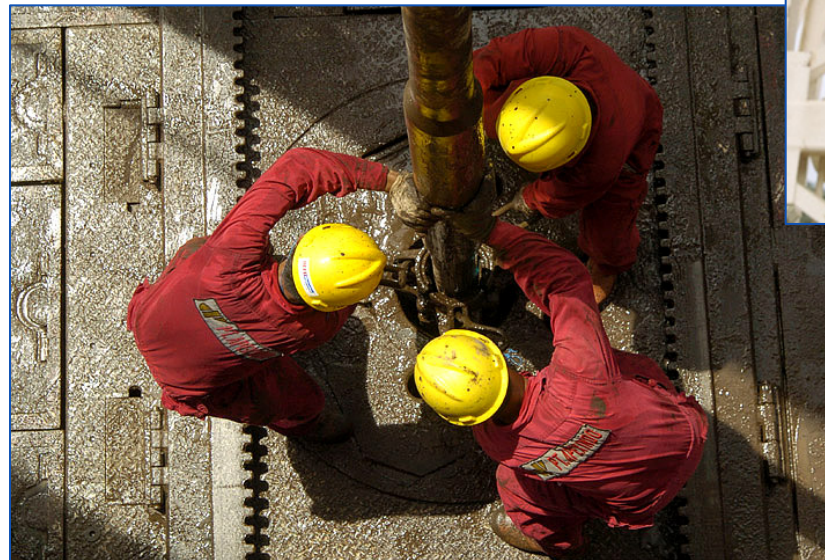

# Choosing a suitable drilling bit

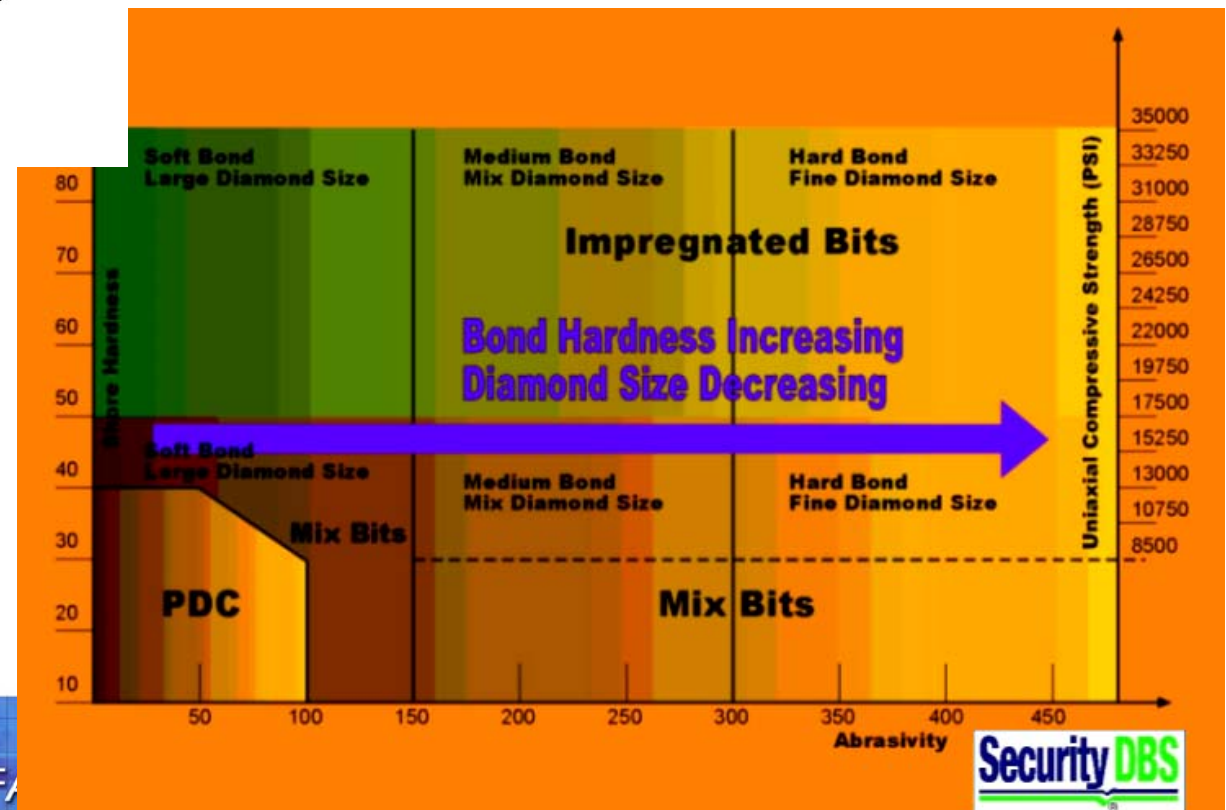
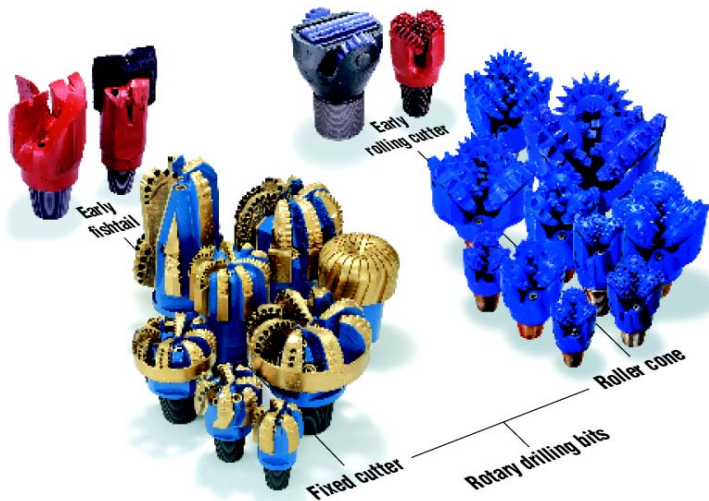

# Qualifying drill bits – the case of PDC cutters

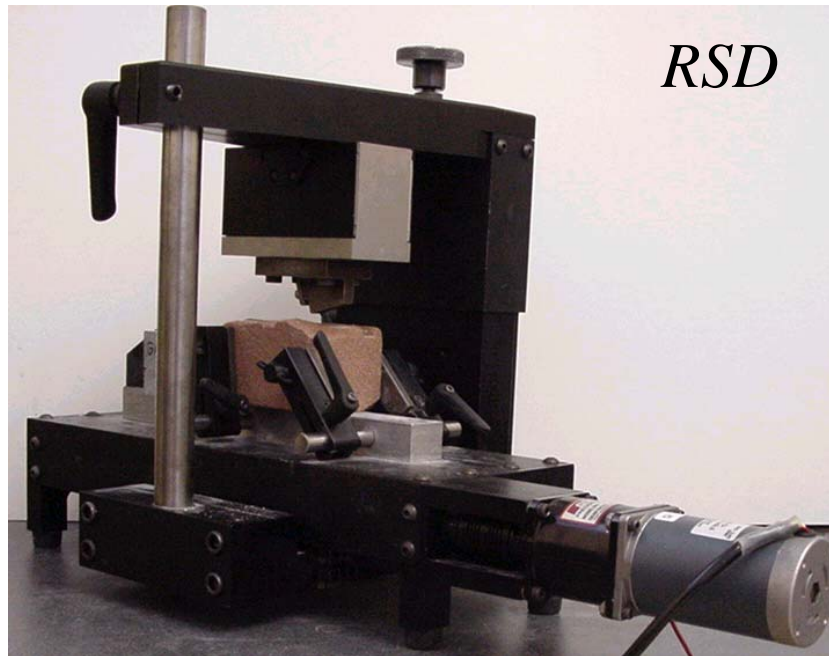

Measure of specific energy  
(intrinsic property of the rock)



Adjustable side and back rake

# Controlling the trajectory of the wells

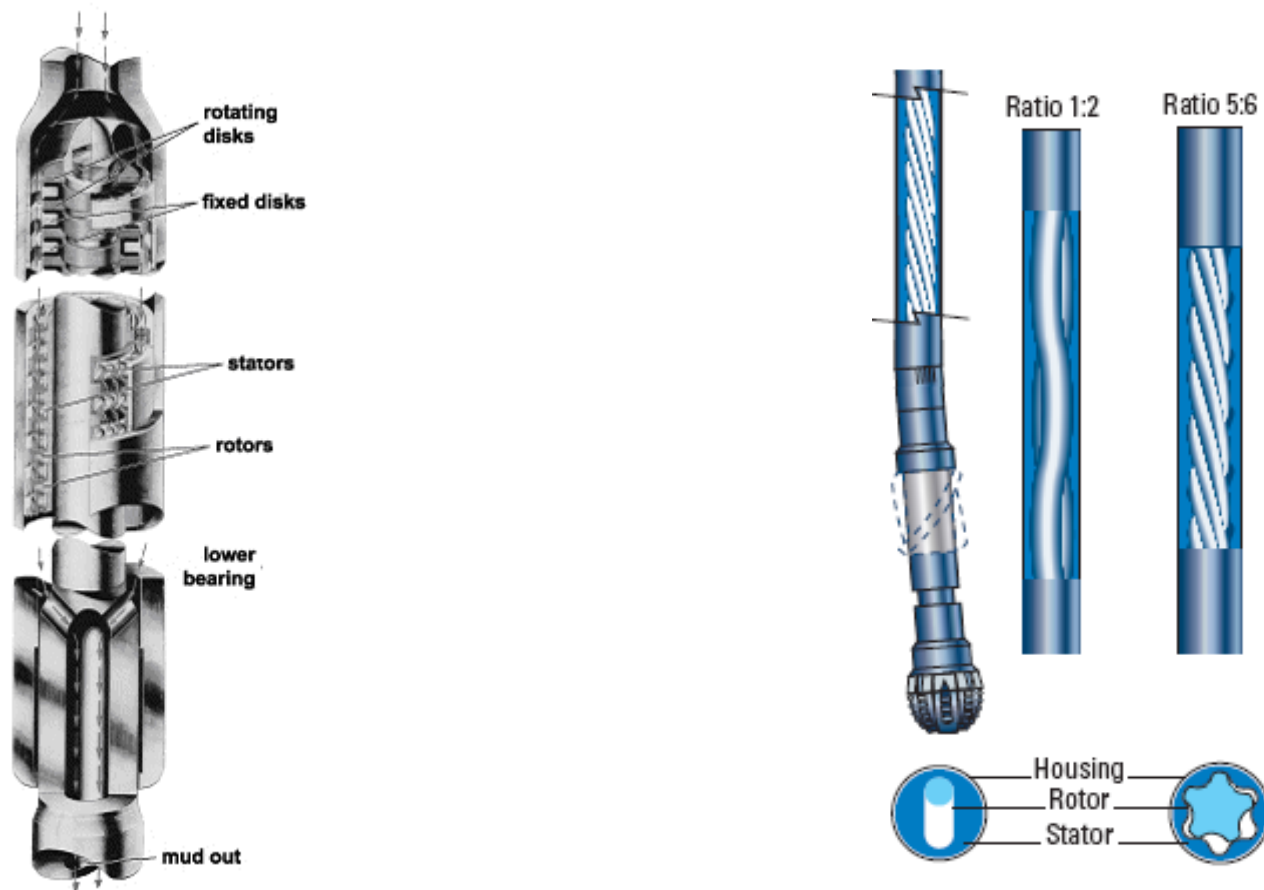

A picture of a drilling turbine (Dresser Industries) and a PDM motor (Schlumberger).



# MWD – Measuring While Drilling

**Directional information:** capable of taking directional surveys in real time by use of accelerometers and magnetometers to measure the inclination and azimuth of the wellbore, and then transmit the information to the surface.

**Drilling mechanics information:** can provide information about the conditions at the drill bit: Rotational speed of the drillstring, Smoothness of that rotation, Type and severity of any vibration downhole, Downhole temperature, Torque and Weight on Bit, measured near the drill bit, Mud flow volume

**Formation properties:** When combined with Logging While Drilling tools, can take measurements of formation properties: density, porosity, resistivity, pseudo-caliper, inclination at the drill bit (ABI), magnetic resonance and formation pressure.

# Horizontal and extended reach wells

From one position (on-shore or off-shore) many targets can be reached using specific techniques (steering motor with MWD equipments).

Vertical depths of 5000m are usual and also horizontal extent of up to 10.000m.

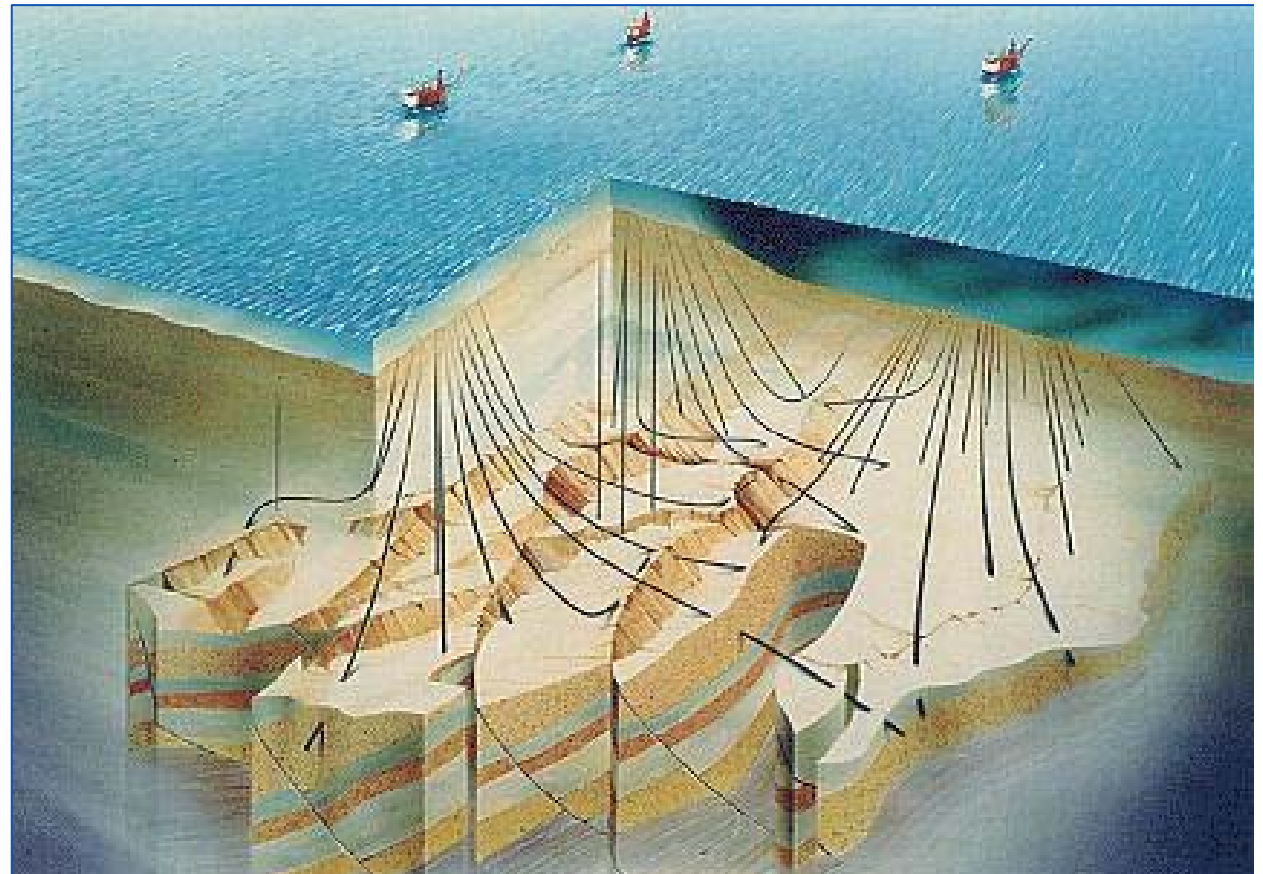

# The drilling mud functions

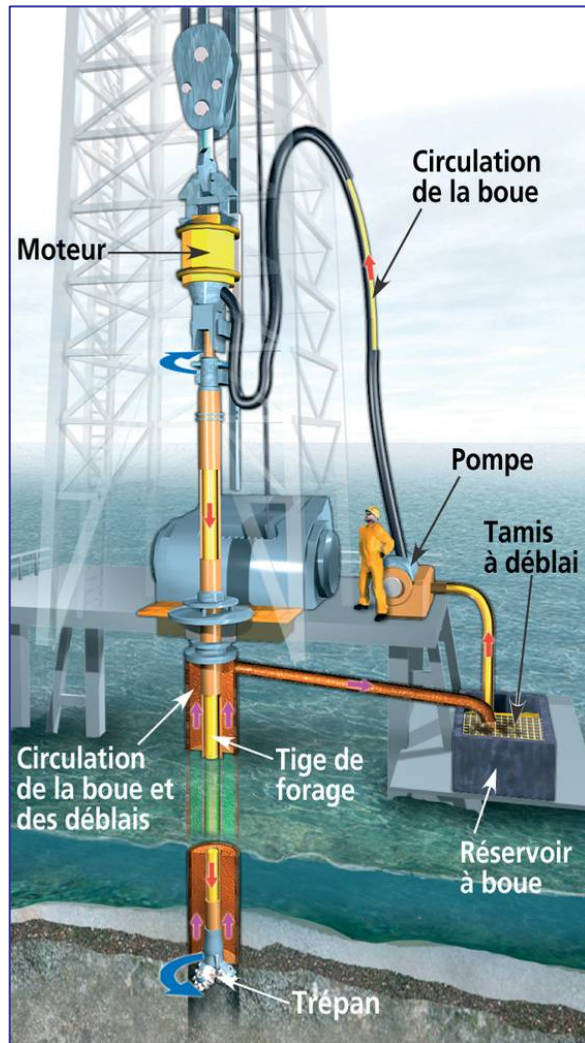

- ❑ Evacuate the cuttings
- ❑ Support the wellbore wall during the drilling phase
- ❑ Can prevent the income of formation fluids
- ❑ Cool the drilling tool
- ❑ Avoid the settlement of cuttings during a stop of the circulation.

# Drilling mud characteristics

- ❑ Flow rate: ensure the evacuation of cutting without re-crushing
- ❑ Density control: supply a support pressure to the walls
- ❑ Thixotropy: forms a gel to avoid settlement during stop of pumping
- ❑ Cake formation (thin layer deposited on the wall): avoid income of formation fluids and also loss of the mud.

## Drilling mud type, composition and use

- ❑ **Water based:** bentonite, water, baryte (densifier), salts to avoid shale swelling, ... - non environmental concerns but can induce clay mineral swelling.
- ❑ **Oil based :** oil, densifiers,... - good for swelling formations but pollute the environment – forbidden in most developed countries.
- ❑ **Polymers:** suitable for all geological formations but are expensive.

# Final support and sealing of the borehole

The final support is supplied by means of a steel casing sealed to the walls by cement. First the casing is introduced in the hole, then the cement is pumped in it and it takes the annular space to go up and seal.

Deep wellbores are drilled in many stages to ensure wall stability (depends on the geomechanical properties of the drilled formation). This obliges a change in the size of drill bit and casing (becoming smaller) when shifting from a stage to a next one.

For the production levels, the casing is to be perforated to give access to geological formations.

**Beware on corrosion problems for long term use in case of CO2 storage.**

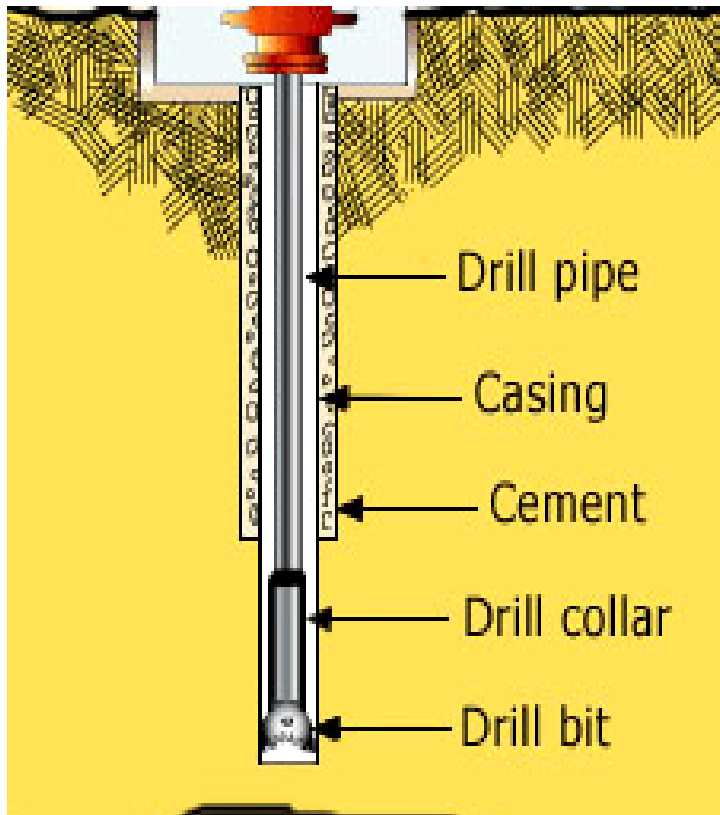

First stage casing  
(i.e. 17 inches)

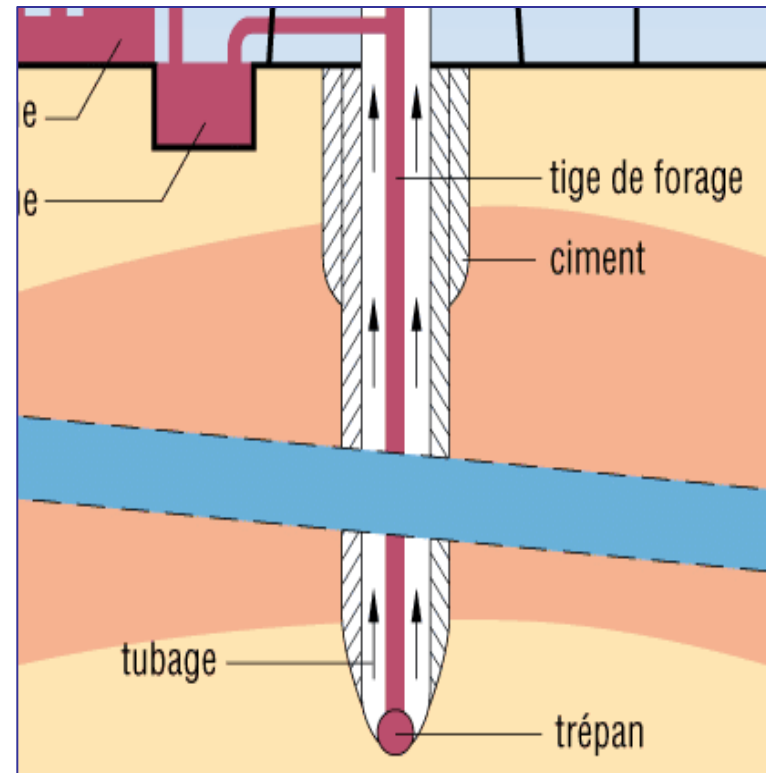

Second stage casing  
(i.e. 14 inches)

# Improving the formation production - Hydro fracturing

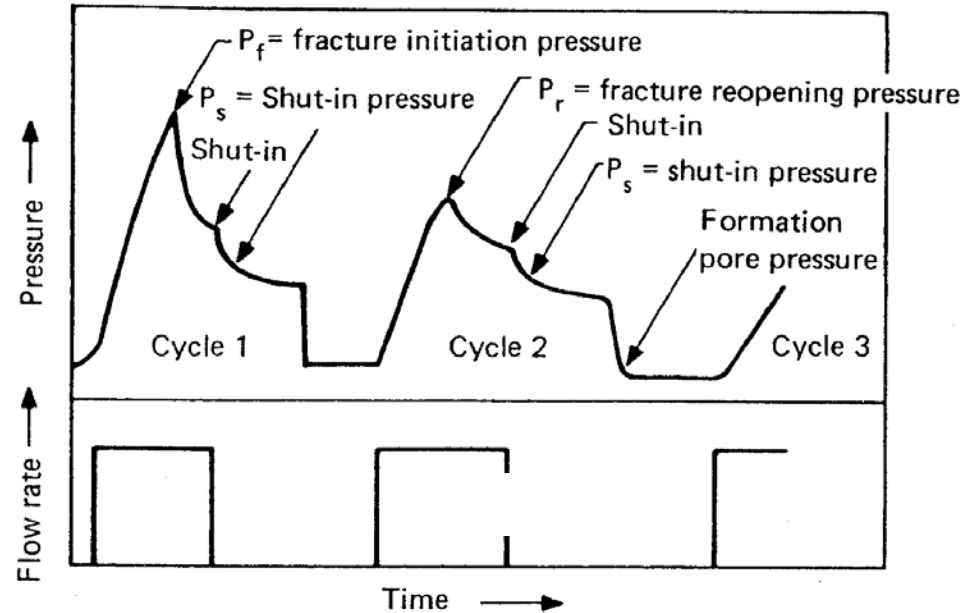
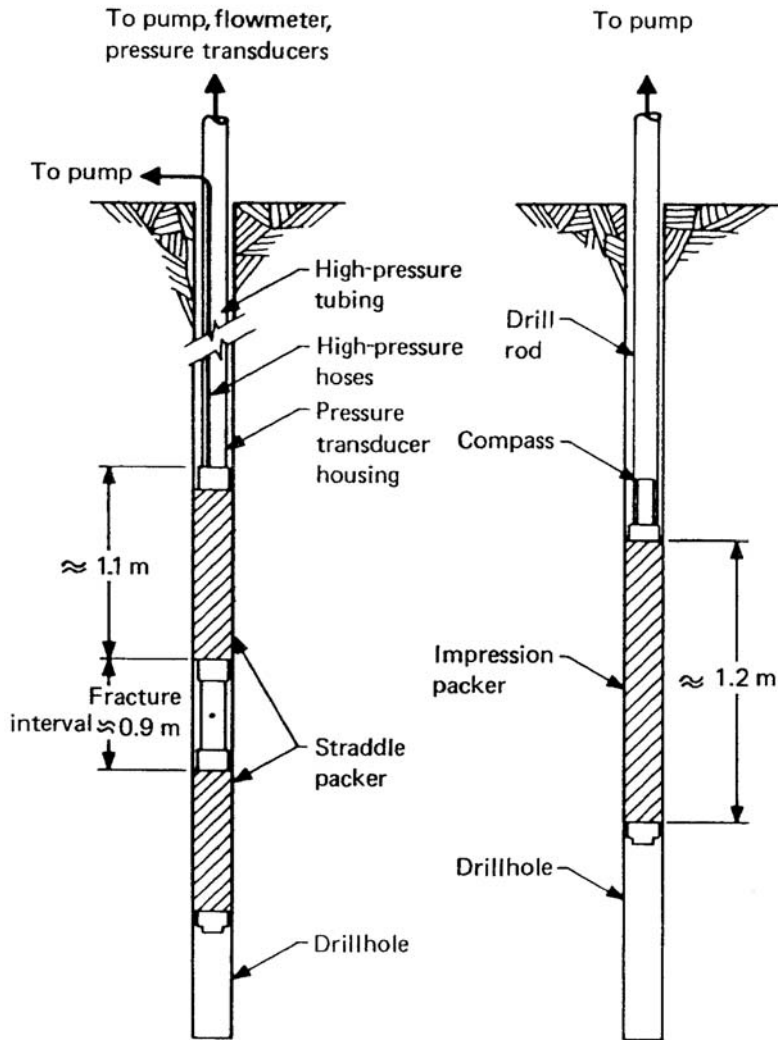

Performing the hydraulic fracturing and also measuring the in-situ stresses



# CO<sub>2</sub> storing in coal formations

## ECBM(R) : Enhanced CoalBed Methane (Recovery)

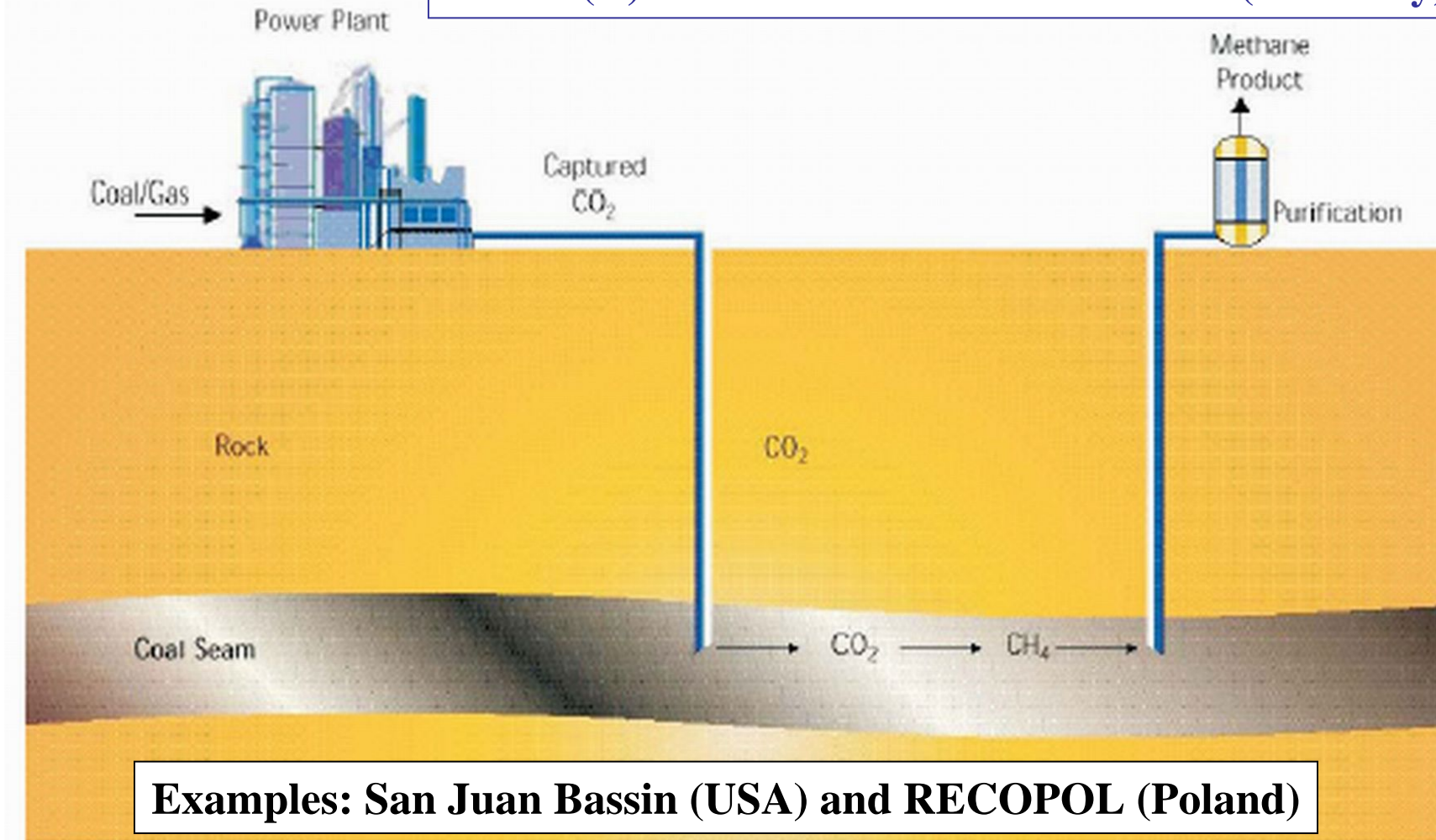

**Examples: San Juan Bassin (USA) and RECOPOL (Poland)**

# CO2 storage and methane recovery

On the technical point of view, the technique is similar to the one used for petroleum reservoirs and deep aquifers.

But mining drilling techniques (smaller drill rigs) can be tried for economical reasons.

Storing in coal will use two physical mechanisms: filling the porous space, and adsorbing CO2 on the coal grain surface.

# Example of the RECOPOL project

International Partnership :

- Partners: involved in the project construction
- End-Users: can access the results and have rights to use them

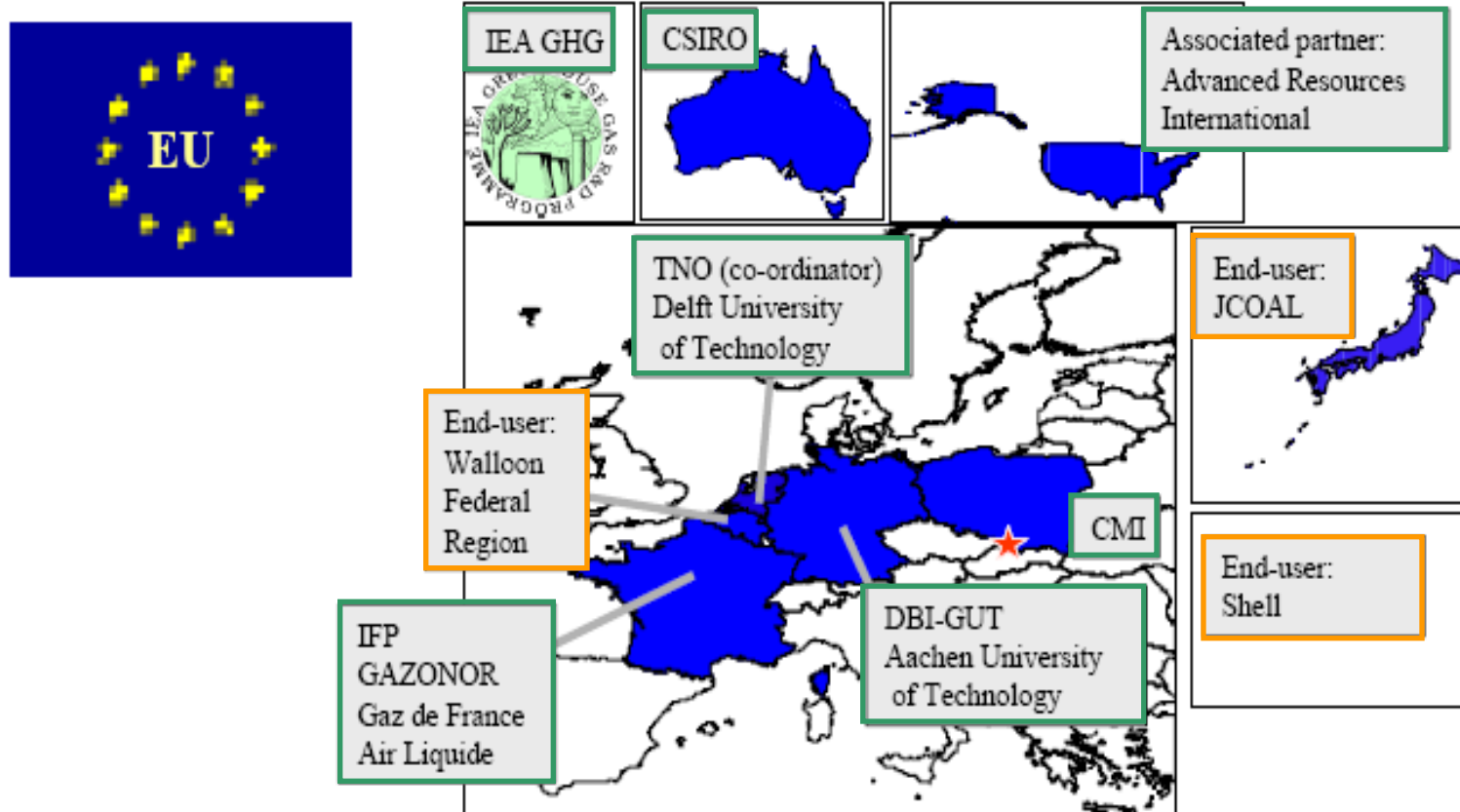

# Technical development of the RECOPOL project

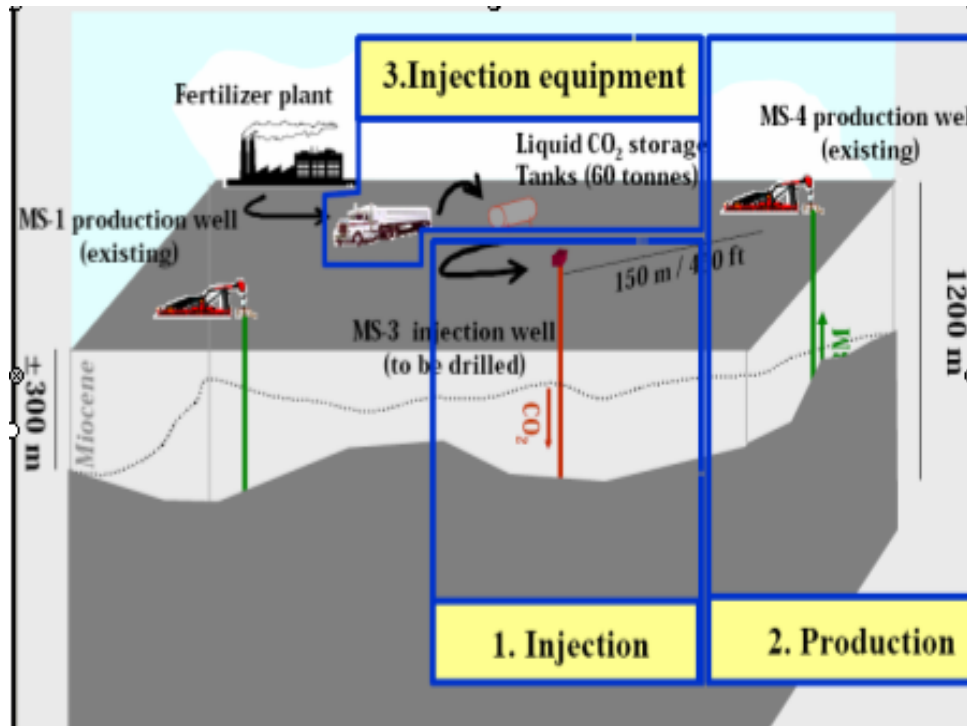

Summer 2003 : development of site

July 2004 : CO<sub>2</sub> injection

Decembre 2004 : breakthrough

Avril 2005 : End RECOPOL 1



Scheme of the equipment for CO<sub>2</sub> injection :

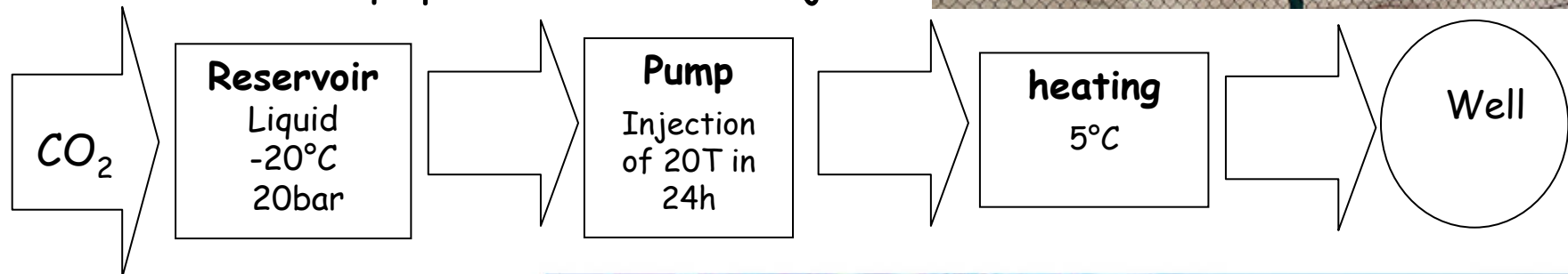

# Problems risen: Shrinkage and swelling

The general results were poorer than assessed.

A decrease in permeability has been observed during injection, an explanation can be given by the shrinkage-swelling mechanisms, so reducing the porosity.

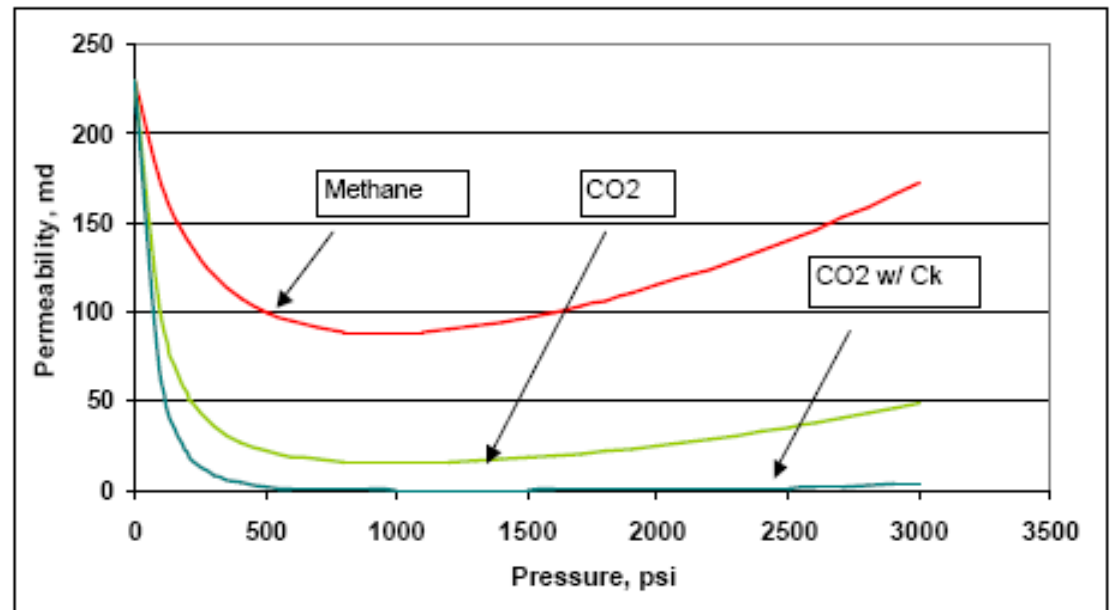

**Shrinkage and swelling**  
**Pekot & Reeves, 2002**

Possible solutions:

- **Hydro-fracturing:** this has been applied and the results improved
- in-seam drilling to improve the access

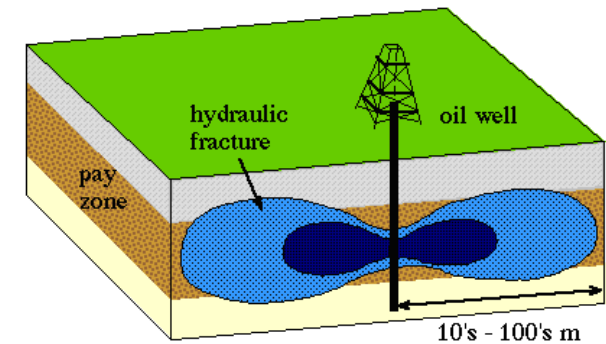
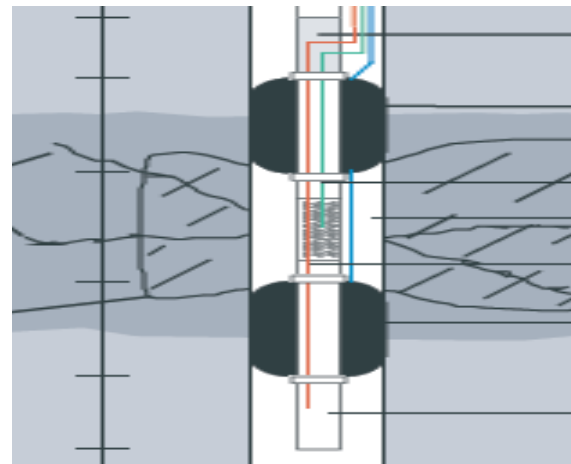
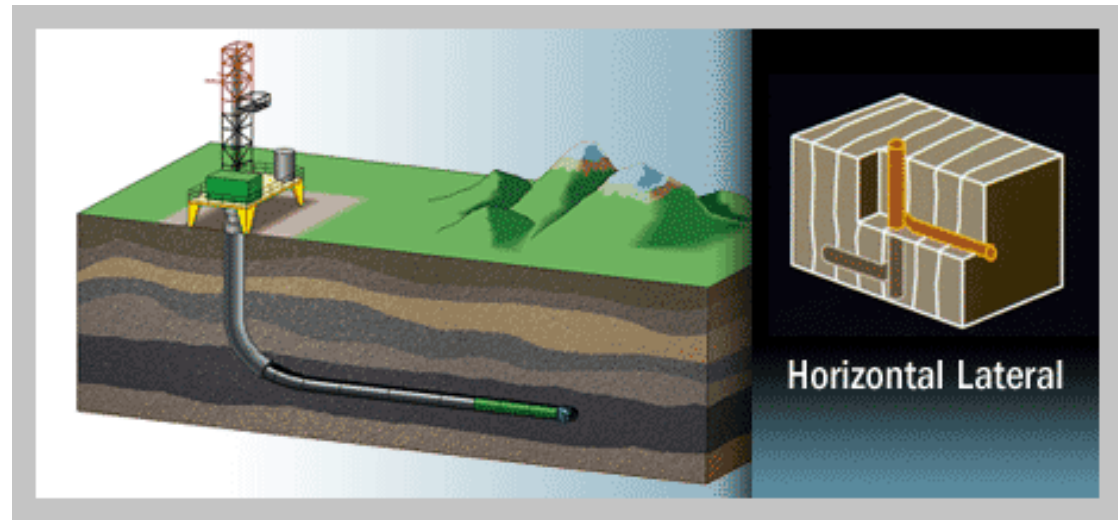

# Transferability in Walloon Region - Belgium

An appeal has been issued by the Walloon Region Government in November 07 for a pilot in situ experiment of CO<sub>2</sub> storage combined with methane recovery.

It must be a public-private partnership and discussion are going to build Economical Interest Group to develop a project.

Private interested partners: electricity, cement, steel and chemical producers

# The geology of the Mons to Charleroi basin

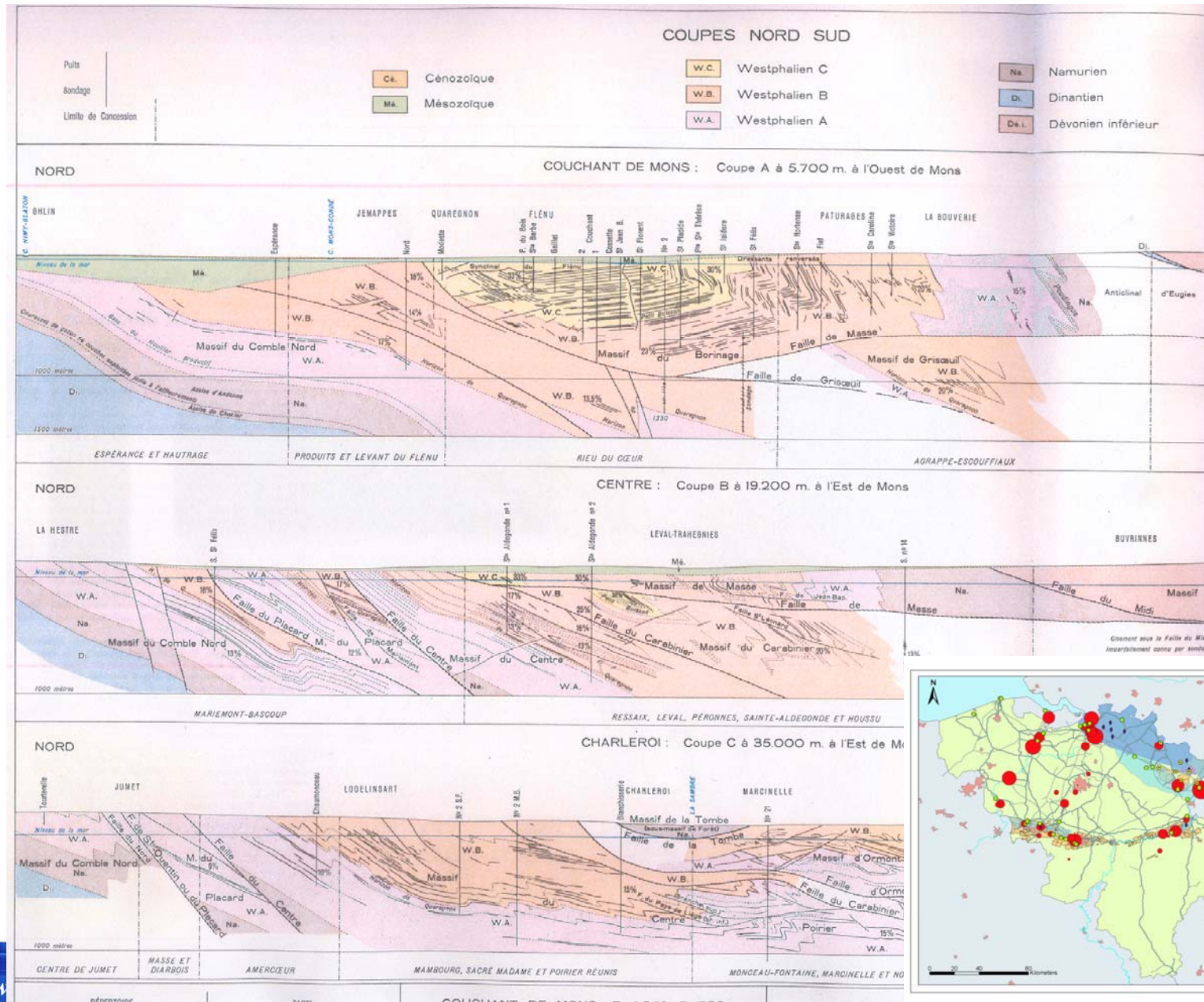



# Storing in abandoned mines

Not recommended because of poor reliability

An example of an abandoned mine shaft : Bois du Cazier Belgium

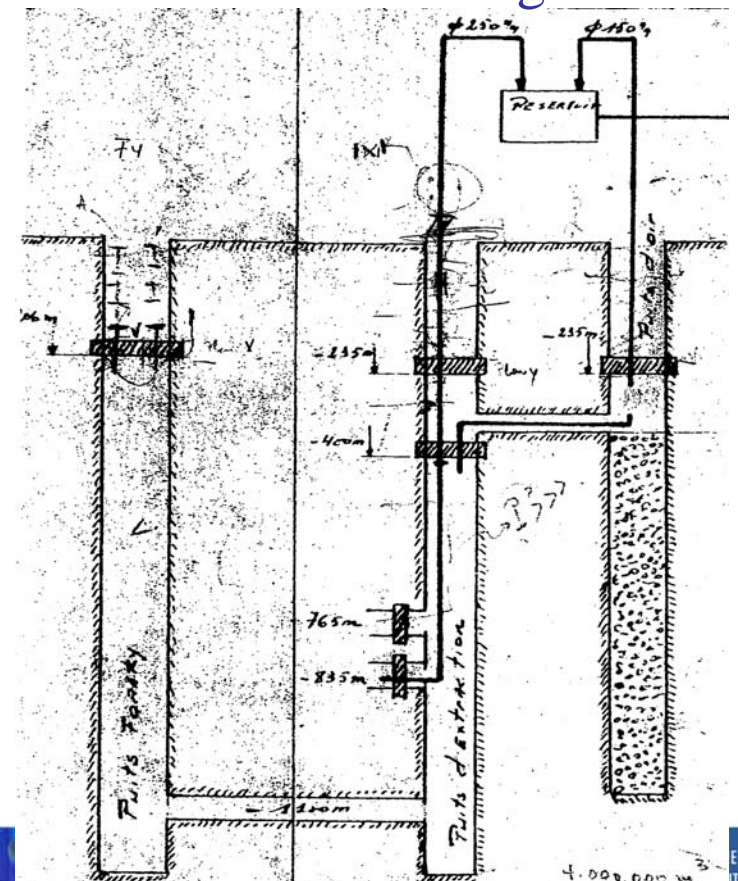
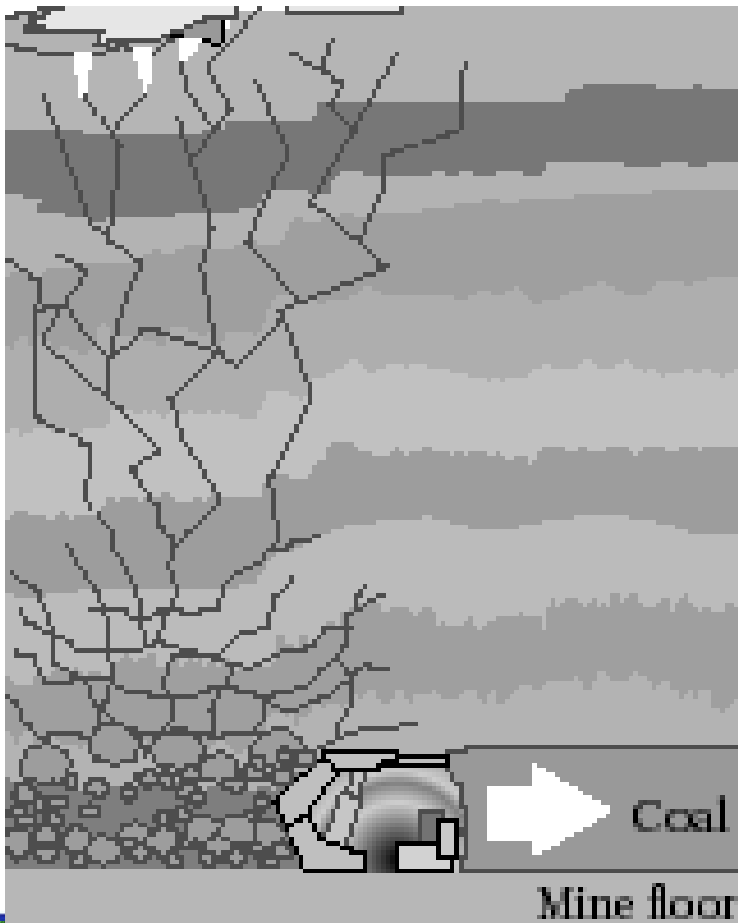

# Thank you for attention

